

Hydro-Turbine Applications Product Manual



TABLE OF CONTENTS

COMPANY PROFILE	1
INNOVATIVE SOLUTIONS FOR HYDRO-TURBINE REHABILITATION AND NEW PROJECTS	2
THORDON HYDRO-TURBINE BEARINGS	
Product and Configurations	3
Thordon Grades	4
Typical Bearing Abrasive Wear Rates	5
General Material Selection Guide	6
Typical Bearing Wear Rate vs. Abrasive Content	7
Design and Installation Considerations	7
Technical Support	8
Thordon Bearing Sizing Calculation Program	8
THORDON LONG LIFE-CYCLE SOLUTIONS, LOWER COST & DOWNTIME	10
APPLICATIONS	
Turbine Main Shaft Guide Bearings	10
Segmented Turbine Shaft Seals	10
Wicket Gate and Operating Linkage Bearings	11
Wicket Gate Thrust Bearings	11
Servo-Motor and Servo-Link Bearings	12
Operating Ring Wear Pads	12
Pump Bearings	12
Control Gate Bearings	13
Butterfly Valve Trunnion Bearings	13
Screen Bearings and Wear Pads	13
Butterfly Valve Seals	13
Servo-Motor and Other Hydraulic/Pneumatic Sealing Applications	14
Seals for Wicket Gate, Operating Mechanism and other Limited Motion Bearings	14
Kaplan Runner Hub Seals	14
REFERENCE STORIES	15
REFERENCES	25
TYPICAL DRAWINGS	37

Note: *The information contained in this document is offered as part of our service to customers. Thordon Bearings reserves the right to revise any information or specifications included in this document without prior notice.*

COMPANY PROFILE

Thordon Bearings Inc., a member of the Thomson-Gordon Group of Burlington, Ontario, Canada, designs and manufactures a complete range of high performance, environmentally-friendly bearings and bearing systems. Recognized internationally for superior performance, Thordon solutions and products are specified extensively in marine, offshore, pump, hydro-turbine and other many other industrial applications in through more than 85 distributors in over 100 countries throughout the world.

Utilizing proprietary polymers developed and manufactured by Thordon as the bearing surface, Thordon bearing solutions deliver high reliability and long wear life, particularly in tough, abrasive operating conditions. This high level of product performance results in decreased life cycle costs and increased mean time between failures for Thordon's customers. A team of experienced, in-house application design engineers provides innovative bearing system designs to meet or exceed each customer's technical requirements. Thordon products and services are available worldwide through local distributors whose factory-trained specialists consult with customers from the establishment of bearing system specifications to ensuring the product is correctly installed and commissioned in the field.

Since the turn of the century, Thordon Bearings' parent company, the Thomson-Gordon Group, a fourth generation family-owned business, has recognized the importance of providing industry with superior products, precision manufacturing and solid application engineering support. Thordon Bearings' own engineering and quality focus has earned worldwide recognition from its many customers. Quality procedures are certified to ISO 9001:2008 Quality System requirements.

Thordon bearings, and bearing systems, are the proven, cost-effective, environmentally-friendly, solution for rigorous and demanding journal bearing applications.

INNOVATIVE SOLUTIONS FOR HYDRO TURBINE REHABILITATION AND NEW PROJECTS

Thordon Bearings is a pioneer in producing high performance, long lasting bearing and seal system designs that require no oil or grease.

Our elastomer grades (SXL, GM2401, HPSXL) offer the best combination of strength/stiffness with flexibility/elasticity and abrasion resistance. The thermoplastic grade (ThorPlas-Blue) is a full form bearing that can operate at higher pressures than Thordon elastomers. Regardless of grade or configuration, Thordon bearings do not require oil or grease lubrication in dry or wet conditions.

- Long wear life and lower maintenance costs mean lower life-cycle costs
- Self-lubrication eliminates pollution risk
- Superior customer service means quick delivery and less downtime
- Full-cycle technical support includes system design, machining, installation and after-sales service
- Certification to ISO 9001:2008 ensures consistent custom and stock solutions

Thousands of customers across the world, in both rehabilitation and new turbine projects, know Thordon Bearings is the proven choice for performance and value. Thordon bearings last.

Zero Pollution Bearing Systems

Thordon bearings help preserve the natural environments in which they operate. Our bearings and seals are pollution-free solutions.

- No oil or grease lubrication, wet or dry
- Extremely long wear life
- Reliable - no headaches with grease lines failing

High Performance Bearing Solutions with No Oil or Grease.

PRODUCT AND CONFIGURATIONS

Thordon has developed two types of polymer bearings and several grades that allow selection of the optimal bearing for your unique application.

Elastomeric Bearings

Thordon Bearings introduced a proprietary, elastomeric, synthetic polymer alloy more than 30 years ago originally for use as a sleeve bearing for vertical pump applications. The unique polymer structure yields basic properties more in line with those you could expect from a very high performance rubber if one existed. However, Thordon is harder - yet elastomeric, tough and resilient in nature, self-lubricating with a much lower coefficient of friction and able to accommodate much higher specific pressures than rubber.

Thordon elastomeric bearing grades are not reinforced with layers of woven fabric, rather, it is a fully homogenous product with all properties consistent throughout the entire wall thickness of the bearing. Compared to other non-metallics such as phenolic laminates, Thordon is somewhat softer and more compliant. As a result, under slight misalignment conditions where edge loading is created, Thordon is able to deform slightly, allowing the load to be distributed over a larger area. The localized pressure on the bearing edge is significantly reduced. Due to its elastomeric nature, Thordon is also able to withstand higher degrees of vibration and shock loading without incurring permanent deformation or damage. Thordon offers three elastomeric grades and two configurations

Continuous research over the years has resulted in development of four different bearing-grade elastomer products - XL, SXL, HPSXL and GM2401. This allows selection of an optimum solution based on matching product characteristics to the specific application requirements.

ThorPlas-Blue Thermoplastic Bearings

ThorPlas-Blue is a proprietary, engineered thermoplastic bearing product. While the Thordon range of high performance elastomeric bearing products clearly offers superior performance in the applications in which they can be specified, there are technical limits, such as maximum temperatures and pressures beyond which they cannot be used.

To address this issue, Thordon Bearings introduced ThorPlas-Blue, which significantly expands the range of applications where Thordon bearings can be specified, while still maintaining many of the recognized Thordon performance advantages.

When compared to the Thordon elastomer-based products, ThorPlas-Blue offers:

- increased strength and rigidity allowing maximum dynamic working pressures up to 45 MPa (6527 psi) in a full-form tubular configuration
- improved ability to operate at elevated temperatures up to 80°C (176°F) in water
- improved chemical resistance in all major chemical categories
- enhanced wear life in non-abrasive environments

In Powertech tests, ThorPlas-Blue demonstrated exceptional wear performance particularly in the dry tests. According to Powertech, there was little evidence of stress on the bearing material and no indication of damage to the journal surfaces.

THORDON GRADES

ThorPlas-Blue

- Engineered thermoplastic for high pressure applications up to 45 MPa (6527 psi)
- Full-form tubular configuration
- Very low wear in non-abrasive environments
- Operates in water up to 80°C (176°F)



Thordon SXL

- Working pressure to 10 MPa (1450 psi)
- Friction coefficient typically 0.10-0.20
- Wet or dry operation
- High resistance to abrasion, shock loading and vibration
- Dry start-up capability



Thordon HPSXL TRAXL

- For high pressure applications up to 55 MPa (8000 psi) dynamic or 70 MPa (10,000 psi) static peak
- Friction coefficient typically 0.06-0.12
- High resistance to shock loading and vibration



Thordon XL

- Maximum dynamic working pressure to 5.5 MPa (800 psi) in limited motion
- Low coefficient of friction (typically 0.20-0.25)
- High resistance to abrasion in dry applications
- High resistance to shock loading and vibration



Thordon Composite (GM2401)

- Made specifically for use in very abrasive water environments
- Stiffer and at least twice the abrasion resistance of rubber
- Lower friction coefficient than rubber



Thordon PT80

- Excellent mechanical property retention (in water), or higher temperatures
- Internal lubricants provide dry run capabilities similar to Thordon SXL
- Wear characteristics similar to existing Thordon elastomer grades
- Low coefficient of friction



Thorseal

- Keep abrasives from bearing surface
- Pressures from 0 -100 MPa (0-15,000 psi)
- Tough - won't cut or tear
- Low friction – self lubricating
- Single and stacked for limited motion and reciprocating linear applications
- Can be custom designed to solve difficult sealing solutions• low friction - self-lubricating



TYPICAL BEARING ABRASIVE WEAR RATES

Rotary Drum Abrasion Test (ASTM D 5963-96)

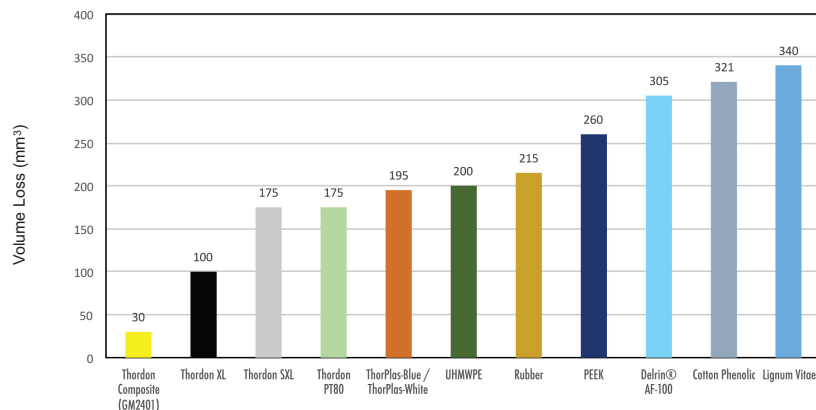

GENERAL MATERIAL SELECTION GUIDE FOR VARIOUS APPLICATION PARAMETERS

Lubrication / Operating Pressure	Recommended Thordon Grades		
	★★★★★	★★★★	★★★
Dry (sealed or minimal abrasives)			
0-10 MPa (0-1450 psi)	SXL / PT80	ThorPlas-Blue	
10-15 MPa (1450-2175 psi)	HPSXL	ThorPlas-Blue	
15-45 MPa (2175-6525 psi)	ThorPlas-Blue	HPSXL TRAXL	
45-55 MPa (6525-8000 psi)	HPSXL TRAXL		
Dry (abrasives present)			
0-5.5 MPa (0-800 psi)	XL	SXL/PT80	ThorPlas-Blue
5.5-10 MPa (800-1450 psi)	SXL / PT80	ThorPlas-Blue	
10-15 MPa (1450-2175 psi)	HPSXL	ThorPlas-Blue	
15-45 MPa (2175-6525 psi)	ThorPlas-Blue		
Wet (sealed or minimal abrasives)			
0-10 MPa (0-1450 psi)	SXL / PT80	ThorPlas-Blue	
10-15 MPa (1450-2175 psi)	HPSXL	ThorPlas-Blue	
15-45 MPa (2175-6525 psi)	ThorPlas-Blue	HPSXL TRAXL	
45-55 MPa (6525-8000 psi)	HPSXL TRAXL		
Wet (abrasives present)			
0-3 MPa (0-500 psi)	GM2401	SXL / PT80	ThorPlas-Blue
3-10 MPa (500-1450 psi)	SXL / PT80	ThorPlas-Blue	
10-15 MPa (1450-2175 psi)	HPSXL	ThorPlas-Blue	
15-45 MPa (2175-6525 psi)	ThorPlas-Blue		
Potable Water (wet or near dry)			
0-3 MPa (0-500 psi)	ThorPlas-White		
3-10 MPa (500-1450 psi)	ThorPlas-White		
10-15 MPa (1450-2175 psi)	ThorPlas-White		
15-45 MPa (2175-6525 psi)	ThorPlas-White		

Note: The maximum pressures given for the various products are based on maximum dynamic working pressures for intermittent, limited motion. For applications involving continuous rotary motion, PV limits of the materials will significantly reduce the maximum allowable pressures stated above.

This is a general guide for technical reference only. Critical applications that are close to pressure or temperature limits, or subjected to non-standard environments should be reviewed and approved by Thordon Engineering.

TYPICAL BEARING WEAR RATE VS. WATER ABRASIVE CONTENT

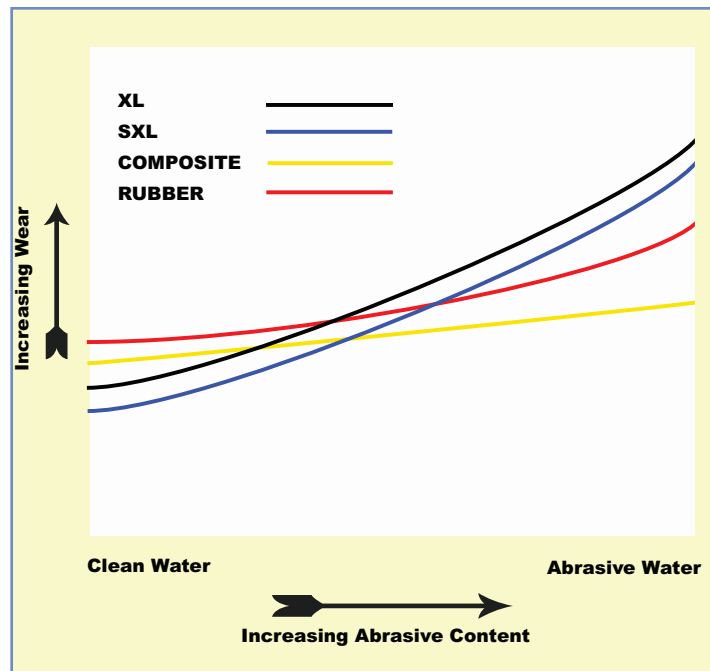

DESIGN AND INSTALLATION CONSIDERATIONS

Before choosing a Thordon grade for an application, the following criteria must be considered:

- speeds (rpm)
- type of lubrication
- pressures
- amount of abrasives
- degree of impact loading
- ambient temperatures (maximum/minimum)
- special ambient conditions (e.g. intermittent exposure to high temperature steam cleaning)
- media temperature (pumps)
- process temperature (pumps)
- pH levels (pumps)
- Thordon has produced a Bearing Sizing Calculation computer program to assist designers in the calculations required to correctly size Thordon bearings (see sample output above)
- Thordon engineers can help in designing bearing solutions and drawings can be provided

TECHNICAL SUPPORT

Thordon Bearings recognizes the importance of superior products, precision manufacturing and application engineering support. Thordon Bearings in-house engineers work closely with customers to provide innovative bearing system designs that meet or exceed the technical requirements of the application. Full engineering drawings are generated as necessary. Thordon has many years of experience with numerous industrial applications in virtually all industries and offers technical support during machining and installation.

Geared to provide quick response to customer needs, Thordon Bearings understands the importance of quick delivery and reduced downtime. Standard size bearings are stocked at the factory and by Thordon distributors around the world. Special sizes or designs can be machined to the exact requirements of the customer and delivered quickly throughout the world.



THORDON BEARING SIZING PROGRAM

The Thordon Bearing Sizing Calculation Program is provided to assist designers in the calculations required to correctly size Thordon bearings. The program input parameters include shaft RPM, interference or bond fit, type of lubrication, type of service, load on bearing, etc. Output parameters include machined bearing sizes and tolerances, amount of interference, bore closure amount, min. installed clearance, running clearance, etc. An example of the Thordon Bearing Sizing Calculation Program output is attached.

Designed to operate on a PC (personal computer), the software operates in the Windows operating system. The program is in a color, menu-based format so that entries can be made with a minimum of effort. Outputs can be printed and inputs can be saved to a file. Contact Thordon or your distributor to obtain a copy of the program or visit our website at <http://www.thordonbearings.com>.

SAMPLE OUTPUT

Thordon Bearings Sizing Calculation Program

No: 901263BM33 V 2006.2
Printed Date: 2/28/2015

THORDON BEARINGS INC.
3225 Mainway Drive, Burlington, Ontario, Canada L7M 1A6
Tel: 905-335-1440 Fax: 905-335-0209, www.thordonbearings.com

General Information

Thordon Distributor: Thordon Head Office
Customer:
Project Reference: Hydro-turbine bearings
Calculated By:
Checked By:
Comments:
Drawing Number:
MRP Number:

Results

=- ATTENTION =-

Method of axial retention must be considered.

	Designed at 21 °C	Machined at 21 °C
Machined Bearing Inside Diameter:	80.70	80.70 mm (For reference only)
Machined Bearing Outside Diameter:	88.48	88.48 mm +0.05, -0.05
Calculated Machined Bearing Length:	113.78	113.78 mm +0.00, -0.25
Bearing Wall Thickness:	3.89	3.89 mm +0.00, -0.05
Amount Of Interference:	0.53 mm	
Bore Closure Factor:	1.100	
Bore Closure Amount:	0.58 mm	
Minimum Installed Diametrical Clearance:	0.12 mm	
Diametric Running Clearance:	0.08 mm	
Diametric Thermal Expansion:	0.03 mm	
Diametric Absorption Allowance:	0.01 mm	
Axial Thermal Expansion:	0.05 mm	
Axial Absorption Allowance:	0.17 mm	
Outside Diameter After Dry Ice Cooling:	88.17 mm	
Note:	Forced press required after Dry Ice cooling. Never immerse a ThorPlas® bearing in Liquid Nitrogen!	

Input Data

Dimension Scale: Metric
Temperature Scale: Celsius
Maximum Operating Temperature: 30 °C
Minimum Operating Temperature: -2 °C
Machine Shop Ambient Temperature: 21 °C
Maximum Shaft Diameter: 80.00 mm
Maximum Housing Diameter: 87.95 mm
Minimum Housing Diameter: 87.95 mm
Housing Length: 114.00 mm
Type of Lubrication: Water
Grade of Thordon Used: ThorPlas®
Type of Service: Ind. Oscillating Rotation
Type of Installation: Interference Freeze Fit
Load on Bearing: 0 kg
Shaft RPM: 0

THORDON - LONG LIFE-CYCLE SOLUTIONS, LOWER COST & DOWNTIME

Now you can cut maintenance costs, reduce downtime and get longer, more reliable bearings. This lowers the life-cycle costs for your core bearing needs.

Thordon's unique polymers outperform other bearings:

- Low coefficient of friction
- Very low wear in abrasive water environments
- High resistance to shock loading and vibration
- High pressure performance to 70 MPa (10,000 psi)
- High resilience

APPLICATIONS

Application: Turbine Main Shaft Guide Bearings
Recommended Grades: SXL and GM2401

Thordon Bearings recommends two bearing grades for use in water-lubricated turbine main guide bearings. Thordon SXL offers the lowest coefficient of friction, superior adhesive wear performance and good resistance to wear resulting from third particle abrasion. GM2401 is specially formulated to provide optimal wear resistance in abrasive-laden water conditions, routinely outwearing rubber bearings by a factor of two or more, yet still exhibiting a significantly lower coefficient of friction compared to rubber.

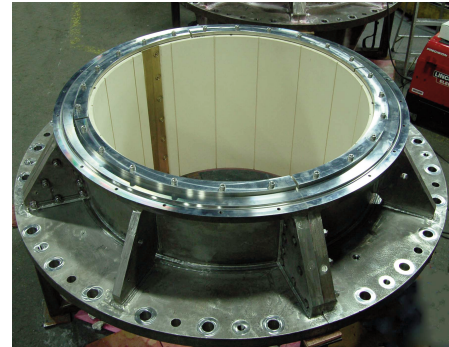

Thordon can be specified as an upgrade for rubber or other non-metallic bearings in existing water-lubricated bearing systems or as a complete conversion from sealed oil or grease lubricated systems to pollution-free water lubrication. Although elastomeric in nature, Thordon bearings, particularly SXL are stiffer than rubber and capable of supporting higher loading. A high degree of resilience, however, is still maintained and running clearances similar to rubber are possible.

Thordon main guide bearings are usually supplied factory-bonded into split bearing housings, or on larger diameter shafts, onto multiple segment blocks. Thordon bearings can also be supplied in stave configuration if required.

Application: Segmented Turbine Shaft Seals
Recommended Grade: SXL

Thordon SXL radial and axial segmented shaft seals provide extended wear life compared to carbon graphite-based seals, particularly when abrasives are present. There is absolutely no risk of damaging a tough SXL seal during installation and overall life cycle costs are

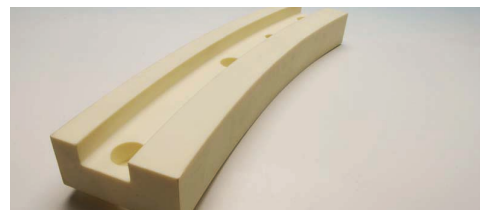

significantly reduced. Thordon segmented shaft seals are supplied molded to size to suit the shaft diameter.

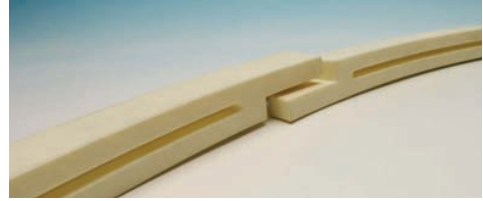

Application: Wicket Gate and Operating Linkage Bearings
Recommended Grades: HPSXL, HPSXL TRAXL and ThorPlas-Blue

Thordon HPSXL TRAXL, or on some smaller machines HPSXL full form bearings are suitable for the lower pressures encountered, are recommended for use in wicket gate and linkage bearing systems. HPSXL, an enhanced elastomer product introduced by Thordon more than five years ago, offers even better friction and wear performance operating either wet or dry than SXL TRAXL. HPSXL TRAXL achieved a top level overall rating in the Powertech simulation tests for wicket gate and operating linkage bearings.



Thordon ThorPlas-Blue is also well suited for wicket gate and linkage bearing applications. An engineered thermoplastic, ThorPlas-Blue can be installed as a full-form product and does not require a bronze shell that HPSXL requires to meet the specific pressure requirements of this application. Also successfully tested by Powertech, ThorPlas-Blue demonstrated very low wear and acceptable friction levels. Where there is a preference for a full form bearing, ThorPlas-Blue is the clear choice for performance and value.

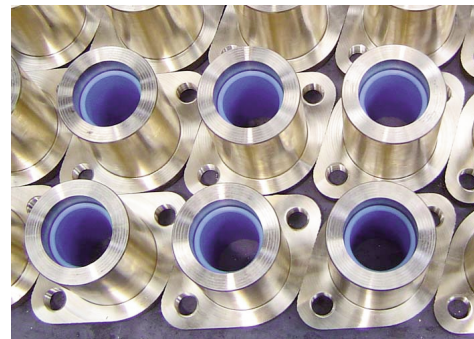

Both HPSXL and ThorPlas-Blue are easily machined and can be supplied either finished to final sizes provided by the customer, or with overbuild to facilitate line boring after installation to correct the misalignment and dimensional consistencies often encountered during turbine rehabilitation.

Application: Wicket Gate Thrust Bearings
Recommended Grade: HPSXL

Thordon HPSXL gate thrust collar bearings eliminate the need for grease required by conventional designs. Elastomeric HPSXL's inherent resilience and low coefficient of friction ensures smooth gate operation with no stick slip. Thordon's designs typically incorporate the thrust bearing into the upper head cover bearing by polymerizing HPSXL onto a flange on the upper bearing, however separate thrust bearings can also be supplied.

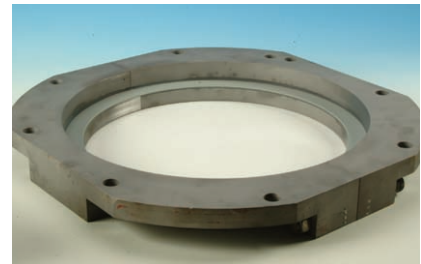

Application: Servo-Motor and Servo-Link Bearings
Recommended Grades: HPSXL TRAXL and ThorPlas-Blue

HPSXL TRAXL bearings are recommended for the servo-motor and servo-link bearing positions. Elastomeric HPSXL is able to accommodate the minor misalignment that often occurs at these bearing locations and grease lubrication can be eliminated.

ThorPlas-Blue is also a good bearing choice for these bearing positions. Self-lubricating and capable of being installed as a full form tube, ThorPlas-Blue also performs well under the edge loading that can occur due to minor misalignment.



Application: Operating Ring Wear Pads
Recommended Grades: SXL and HPSXL

Thordon SXL and HPSXL vertical and horizontal operating ring wear pads offer smooth, grease-free operation and high abrasion resistance. Usually supplied molded to size complete with stainless steel inserts for mechanical fastening, Thordon wear pads can also be bonded in position using a Thordon-approved adhesive.



Application: Pump Bearings
Recommended Grades: SXL, XL, GM2401 and ThorPlas-Blue

Non-polluting Thordon water-lubricated pump bearings offer dry-start capabilities, long wear life, low friction and superior resistance to abrasive wear. Available in four grades, Thordon pump bearings can be selected to optimize specific performance requirements. From Thordon Composite for highly abrasion resistant bottom bowl bearings to Thordon SXL for dry-start upper bearings to ThorPlas-Blue for higher temperature applications, Thordon pump bearings outperform rubber bearings by a factor of two or more in abrasive conditions. Not limited by shelf life or a range of standard production sizes, Thordon pump bearings facilitate quick turn-around and reduced maintenance inventories. Costly sleeve or shaft replacement can often be avoided by machining a pre-grooved Thordon tube to the exact non-standard dimensions required.

A separate Pump Bearing Product Manual is available.



Application: Control Gate Bearings
Recommended Grade: HPSXL

Supplied in ball and socket, or bushing and pad configurations to suit all types of control gate applications, Thordon HPSXL bearings with their low coefficient of friction operate smoothly and easily without grease lubrication. Abrasion resistant and resilient, Thordon bearings provide long wear life and are not damaged by the impact loading resulting from frequent operation.



Application: Butterfly Valve Trunnion Bearings
Recommended Grades: HPSXL TRAXL and ThorPlas-Blue

Thordon HPSXL TRAXL valve trunnion bearings operate smoothly and easily without grease lubrication. ThorPlas-Blue bearings also operate well when specified in this application.

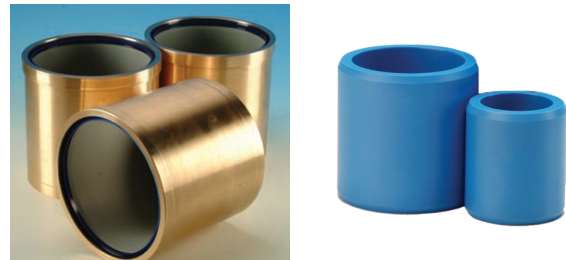

Application: Screen Bearings and Wear Pads
Recommended Grades: SXL, HPSXL and ThorPlas-Blue

Resilient, and highly resistant to abrasion, Thordon SXL is the obvious choice for the shaft bearings and wear pads used in travelling and stationary screens. Non-corroding Thordon bearings offer extended wear life while eliminating the maintenance and pollution concerns associated with grease lubrication. In some designs and locations where pressures may exceed the limit for SXL, HPSXL or, if necessary, ThorPlas-Blue are the recommended options due to their higher pressure capabilities.



Application: Butterfly Valve Seals
Recommended Grade: Thorseal

Highly abrasive resistant, tough, and compliant, Thorseal butterfly valve seals offer extended wear life and are resistant to damage resulting from debris becoming lodged in the valve during operation.



Application: Servo-Motor and Other Hydraulic/Pneumatic Sealing Applications
Recommended Grade: Thorseal

In servo-motor and other hydraulic/pneumatic sealing applications, high performance, tough, Thorseal lip self-lubricating polymer lip seals offer positive sealing up to 100 MPa (15,000 psi). Thorseals provide long wear life with no need for periodic adjustments; resist tearing and extrusion; and as a result of their internal lubricants, operate with less drag and reduced cylinder wear. Thorseals are not only available in a wide range of standard sizes but can also be quickly machined to custom size requirements up to 1.5m (60") in diameter.



Application: Seals for Wicket Gate, Operating Mechanism and other Limited Motion Bearings
Recommended Grade: Thorseal

To prevent contamination of wicket gate, or other hard-to-reach, bearings by abrasive laden waters; or operating mechanism bearings by corrosion residue or other contaminants, seals are recommended. High quality Thorseal lip seals are formulated from a tough, high-strength polymer impregnated with internal lubricants and are supplied as an integral part of the bearing design.



Application: Kaplan Runner Hub Seals
Recommended Grade: Thorseal

Taking advantage of tough, long-wearing Thorseal polymer lip seals, an enhanced sealing design has been developed for Kaplan runner blade hubs. Essentially, two specially designed Thorseal single ring U-cup seals are locked together to function as a monolithic double-acting seal and fitted back to back in the blade shaft stuffing box. The outer seal lip prevents ingress of water into the hub contaminating the lubricating oil and the inner seal prevents oil from leaking out of the hub into the environment. This design is easy to install, resists distortion during blade re-positioning and the modified lip design insures positive sealing under conditions of significantly more blade droop than conventional packing. Shaft wear is reduced due to the friction and wear reducing additives in the polymer and the seals can be supplied split for easy in-situ replacement.





Raanaafoss Rehabilitated with Oil-Free Main Guide Bearing Solution

Well engineered, cost-effective and water lubricated main guide bearing solutions for rehabilitation project

Originally built in 1922, the Raanaafoss I Power Plant in Norway recently began a rehabilitation project to update the plant's performance and render it more environmentally friendly. In keeping with this goal, the plant, now called Raanaafoss III has been fitted with Thordon SXL water lubricated main guide bearings and segmented shaft seals.

The selection of a water lubricated solution for the lower guide bearing instead of the more traditional oil lubricated design allows the bearing to be lubricated with the same river water which is powering the turbine. This completely eliminates the risk of oil leaking from the bearing assembly,

IN THIS ISSUE...

- 1** Raanaafoss Rehabilitated With Oil-Free Main Guide Bearings
- 3** Vertical Lift Pumps Now Fitted With Grease-Free SXL Bearings
- 4** Roll-Off Trucks Keep On Rolling With HPSXL TRAXL
- 5** SXL and Thor-Flex Improve Bearing Wear Life
- 6** Thordon Rides The Trolley Bus
- 8** SXL Saves Pulp And Paper Mill Thousands Of Dollars

REFERENCE STORIES

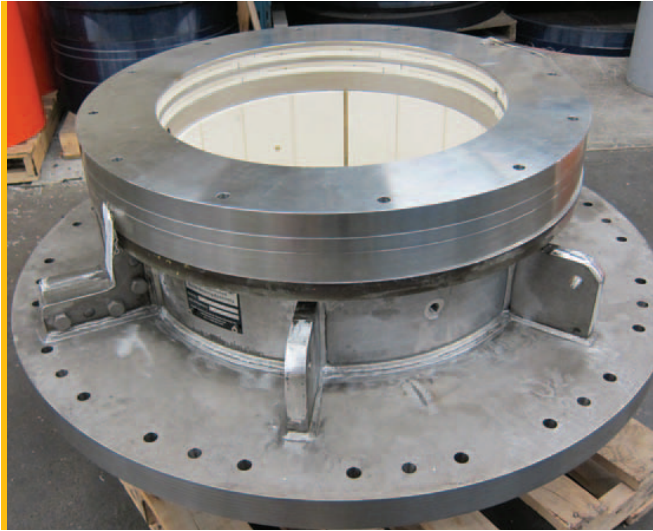

Thordon SXL water lubricated main guide bearing and segmented shaft seals installed in carrier

travelling down the shaft past the packing gland and contaminating the turbine's discharge or tailwater. Not only does converting a turbine from oil to water help protect the environment, it also brings operational and maintenance advantages over the original oil lubricated bearing system.

The series of new turbines, all supplied by Voith Hydro, are to be installed as an extension of the present turbine house. The scope of supply includes six vertical propeller turbines, each with a maximum output of 15.5 megawatts. Commissioning of the first unit was completed in December 2012 and the last unit will be operational by spring of 2016.

Voith Hydro, one of the world's largest turbine manufacturers, started 3 years ago performing a study to evaluate different upgrading possibilities for the old Raanaasfoss power plant. Voith turned to Thordon Bearings for complete turn-key water lubricated main guide bearing assembly.

Thordon was tasked with providing a design solution for the whole assembly using water as the lubricant instead of oil. The use of water as an alternative to oil lubrication is a long standing area of expertise for Thordon with their non-metallic bearings in operation in the hydro industry for over 30 years. The environmental impact was a concern for the project and Thordon's water lubricated bearings seemed to be the right fit for both their technical requirements and environmental mindset.

The bearing design for the Raanaasfoss units focused on providing a fully hydrodynamic bearing design with

adequate support to carry the expected loading while integrating Thordon's unique tapered keyset feature for fixing the polymer bearing directly into the fabricated stainless steel bearing housing without the use of adhesives or additional mechanical fastening. This eliminates the need for a separate bronze bearing carrier while still retaining the ability to replace the split bearing shell without requiring disassembly of the large bearing support housing. The reduction in the complexity and total number of components in the assembly results in quite a substantial savings in cost. The use of the Thordon tapered keyset greatly reduces downtime during bearing inspection or replacement as it facilitates easy removal of the polymer bearing shells without removing the shaft or bearing housing.

"Our previous experiences with projects of this nature are what helped position us as experts in the field. Our overall design proposal was selected because it met the technical

requirements, offered several unique design advantages, and provided an effective way to reduce cost by eliminating a large amount of bronze from the original design," says Greg Auger, Business Development Manager - Clean Power

Generation at Thordon Bearings. "Turbine designers who choose to use a hydrodynamic water lubricated main guide bearing solution will not only gain environmental advantage over their competitors but can find a cost and technical benefit as well."

The use of water as an alternative to oil lubrication is a long standing area of expertise for Thordon with their non-metallic bearings in operation in the hydro industry for over 30 years.

In order to maximize the effectiveness of the lubricating water being delivered to the bearing, the recommendation was made to fit a Thordon SXL segmented shaft seal above the bearing assembly to prevent entry of unfiltered river water into the bearing space. The open-loop design allows the water to be delivered to the top of the bearing, directed down through the bearing space, and then exit directly to the runner. This simplistic yet effective design prevents build-up of abrasives, cools and lubricates the bearing, and maintains a conditioned bearing space to ensure long and predictable bearing life. **NW**

GENESIS OPTS FOR OPTIONS

When one of your hydro turbines had been installed back in the 1930s, and it was time to refit, you want technologies that offer the maximum amount of options, since there really is no way of telling what you are going to find . . . like Thordon's highly engineered crystalline thermoplastic - ThorPlas.

Genesis Energy completed a refurbishment project of Generators 1, 2 and 7 at their Tuai Power Station in New Zealand during March of 2009. This station is a part of Genesis' Waikaremoana hydro generation scheme on the country's North Island.

ThorPlas was chosen as the best option for upgrading their Francis turbines.



ThorPlas wicket gate bearings

The ThorPlas bearings were prepared for the wicket gates (top, bottom and middle positions) by measuring each individual housing, then machining twenty-four tailored fits. Genesis also designed a simple retaining lip (shown in picture) that added another level of axial retention.

Link and servo motor bushes were replaced with ThorPlas bearings as well.

We asked Ian Meredith, the Genesis Hydro Engineering Team Leader why he chose ThorPlas? Ian



ThorPlas bearing installed in retaining lip

explained to us: "First of all, I researched the material and called up some peers in the New Zealand hydro industry who had already used ThorPlas. I received favorable reports about it."

"I found that ThorPlas enabled close fitting clearances. It didn't have to be thin-walled. Neither did it need an outer shell, or liner. We could order it in tube form and have our installation contractor machine it to our specifications exactly as we needed it – a definite plus when refurbishing existing machines.

Our contractor MB Century found it easy to machine, with no toxic dust. To install the bearing they simply followed Pacific Driveline's advice to freeze the bearing using dry ice. Then they either, pushed it in lightly, or tapped into the wicket gate housing . . . making it so easy to complete the job.

These weren't the only pluses. When everything was installed; we found that less force was required to move the wicket gates, so the friction component was reduced.

During the project we found we needed more ThorPlas than was

originally planned for; and we wanted link bearings and servomotor link bearings done as well.

Pacific Driveline was terrific to work with. They had the extra material sent from Canada and out to us within the time frame we required; so the machines weren't left out of service when they could have been generating for us." **NW**

"These weren't the only pluses. When everything was installed; we found that less force was required to move the wicket gates, so the friction component was reduced."



ThorPlas bearings installed in Francis Turbine at Tuai Power Station, New Zealand

S.M.U.D. HYDRO WORKERS FIND NEW USES WITH THORDON BEARINGS



It was late 2007, and the White Rock Powerhouse was overdue for an overhaul. Two of the largest hydroelectric generating units operated by the Sacramento Municipal Utility District (SMUD),

California, U.S.A. were to be shut down for extensive repairs.

Among the necessary repairs, the wicket gate liner plates had to be replaced. High-pressure water had eroded them over the years and was costing thousands of dollars a day in water leakage. Having the machine open would also present a rare opportunity to inspect, repair and upgrade other components that are not normally accessible, such as the wicket gate bushings.

The 40 wicket gates – each weighing 1,500 pounds – have sleeve-like bushings that support the shafts. The original bronze bushings require

constant lubrication from grease lines. Grease is also supplied to numerous bushings that make up the gate operating mechanism. Although the SMUD facility was using organic, vegetable-based jelly grease, not considered a harsh pollutant like petroleum, the use of grease as a lubricant had created quite a housekeeping issue in the units turbine pits.

Significant grease had accumulated in each turbine pit, coating various parts and surfaces. Before proceeding with the disassembly, crews spent five days removing 40 years' worth of grease ultimately filling two 55-gallon (208 L) drums two-thirds full.

"It was quite a mess, and an unsafe place to work," says Bill Collins, Principal Mechanical Engineer in SMUD's Power Generation department. "These guys were in their coveralls, covered in grease and pumping it into containers. The prospect of eliminating the grease lubrication system was clearly attractive, not just because it was difficult to work in there but because it looked terrible."

Once the first machine was disassembled, the crew set out to replace the greased bushings with Thordon's bronze-backed HPSXL TRAXL bearings, which require no maintenance and run grease-free. They started with the 20 wicket gates, each of which has a lower, an intermediate and an upper bushing, thereby eliminating 60 grease points. Next, at the upper stem of the wicket gate is a thrust cap that secures the wicket gate lever as it rotates between the open and close positions. Engineers machined the thrust caps to provide a smooth surface for a Thordon SXL washer to ride against, and installed the washer over the gate lever flanges thereby eliminating 20 more grease points. Collins and his foreman came up with that idea – a custom job that eliminated a grease point beyond what was outlined in

Thordon's product catalogue. "The crews got really excited about the process of eliminating 60, then 80 grease lines, and we thought there were certainly other things we could do," says Collins. "Then we got really carried away."

They decided to use ThorPlas, a thermoplastic grease-free bushing from Thordon, to replace the small sleeve bushings installed within the link levers for the gate operating mechanism, eliminating yet another 40 grease points. In addition, the servo connecting rod bushings and the PRV connecting rod bushings were replaced with ThorPlas greaseless bushings.

The crew has now completed work on both units. Not only are the units free of grease, but the turbine pits look new, with freshly painted gate levers, gate arms, floors, and walls.

The new bearings are expected to outlast the previous, greased ones. Collins, who set out to reduce leakage from the Powerhouse, says the Thordon bearings provided the added bonus of minimizing the greased systems used for lubrication at the powerhouse.

"It's kind of nice to be able to complete your work in such a nice looking area and take pride in it," he says, "without any grease on the horizon." 



White Rock refits with grease free ThorPlas bearings

REFERENCE STORIES

MORE POLYMER SHAFT SEALS ORDERED BY CHINESE TURBINE INDUSTRY

Dongfang Electrical Machinery Co., Ltd (part of Dongfang Electric Corp.) and Harbin Electric Machinery Co., Ltd. have recently placed additional orders for Thordon SXL elastomeric polymer segmented turbine shaft seals bringing the total on order or already installed in 2005, to six sets. The shaft seals sold by Proco International Co. Ltd., Thordon's exclusive Distributor in China, are/will be installed at the Kangyang, Sanbanxi, Xiafu, Baishan and Nalan power plants in China and the Tekeze Hydropower Plant in Ethiopia. Sealing large hydro turbine shafts



SXL Segmented Shaft Seal

from 400mm up to 2000+mm (16 up to 80 in.) diameter can be a maintenance challenge for power plant operators. Typically, turbine seals consist of two or three sets of stacked segmented carbon rings that can be difficult to install without breakage and can be subject to relatively short life if misaligned or subjected to abrasives.

Since its first shaft seal installation in 1982 at the Manapouri Power Station

in New Zealand, Thordon Bearings has compiled a history of segmented shaft seal installations. In 2003, Thordon embarked on a program to further optimize its segmented shaft seal design utilizing its proprietary SXL material. SXL is formulated using a tough elastomeric synthetic polymer alloy offering ease of installation, high natural abrasion resistance and good sealing performance.

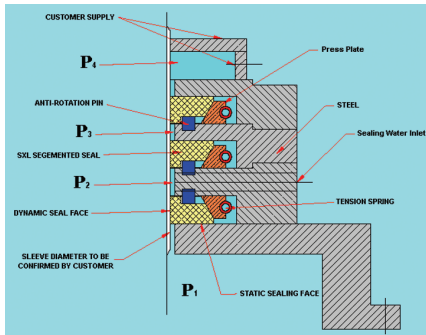

SXL Segmented Shaft Seal References

Customer	Power Plant/Dam	Country	Seal Type	Turbine/Pump	RPM	Shaft Diameter (mm)	Shaft Diameter (Inches)	Install Date
Itaipu Binacional	Itaipu	Brazil	Axial			3770 mm	148.43	Oct. 2005
Dongfang Electric Machinery Co., Ltd	Nalan	China	Axial	Francis		892mm	35.12	Oct. 2005
Harbin Electric Machinery Co., Ltd.	Baishan	China	Radial	Pump Turbine	200	1015 mm	39.96	Aug. 2005
Harbin Electric Machinery Co., Ltd.	Xiafu	China	Radial	Francis	107	1170 mm	46.06	Apr. 2005
Harbin Electric Machinery Co., Ltd.	Sanbanxi	China	Axial	Francis	166	1532 mm	60.31	Mar. 2005
Dongfang Electric Machinery Co., Ltd.	Tekeze Hydropower Plant	Ethiopia	Radial			1160 mm	45.67	Mar. 2005
Dongfang Electric Machinery Co., Ltd.	Tekeze Hydropower Plant	Ethiopia	Radial	Francis	300	1160 mm	45.67	Mar. 2005
Harbin Electric Machinery Co., Ltd.	Kangyang	China	Axial	Horizontal	125	970 mm	38.19	Mar. 2005
Meridian Energy	Manapouri Power Station	New Zealand	Radial			910 mm	35.83	Jan. 2005
Infraserv Hochst		Germany				2060 mm	81.10	Oct. 2004
Harbin Electric Machinery Co., Ltd.	Nrji	China	Radial	Francis	107	1170mm	46.06	Jan. 2004
Harbin Electric Machinery Co., Ltd.	Bian	China	Radial	Kaplan	22.5	2380 mm	93.70	Nov. 2003
Dongfang Electric Machinery Co., Ltd.	Fenshuijiang	China	Radial	Horizontal	166	720 mm	28.35	Jul. 2003
Harbin Electric Machinery Co., Ltd.	Gongboxia Power Station	China	Axial	Francis		1820 mm	71.65	Mar. 2003
California Department of Water Resources	San Luis Dam	U.S.A.	Radial			940 mm	37.01	Mar. 2003
China Power Complete Equipment Co., Ltd.	Gongboxia Power Station	China	Axial	Francis		1820 mm	71.65	Feb. 2003
Harbin Electric Machinery Co., Ltd.	Huilong Power Plant	China	Radial	Pump Turbine	750	620 mm	24.41	Feb. 2003
US Bureau of Reclamation		U.S.A.	Radial	Toshiba Turbine		792 mm	31.18	Jan. 2003
Harbin Electric Machinery Co., Ltd.	Bangliang	China	Axial	Francis		892mm	35.12	May. 2002
Harbin Electric Machinery Co., Ltd.	Kulun I	China	Axial	Francis		1526mm	60.08	Jan. 2001
Mighty River Power	Mararetai Power Station	New Zealand	Radial			635 mm	25.00	Jul. 1999
Snohomish Co. P.U.D., Washington	Henry M. Jackson Project	U.S.A.	Axial	Francis Turbine				Nov. 1998
Northern Wasco Co. P.U.D., Oregon	McNary Dam	U.S.A.	Radial			650 mm	25.59	Aug. 1998
LA Dept. of Water Power (LADWP)		U.S.A.	Radial			499 mm	19.65	Sep. 1997
Genesis Power	Rangipo Power Station	New Zealand	Radial			644 mm	25.35	Dec. 1996
Seattle City Light, Washington	Centralia City Light Power Plant	U.S.A.	Radial		400	337 mm	13.27	May. 1996
Central Arizona Water Conservation District	Havasu, Colorado River	U.S.A.	Radial	Htachi pump	514	1067 mm	42.01	Jul. 1995
Mighty River Power	Arahatia Power Station	New Zealand	Radial			755 mm	29.72	Jan. 1992
Hydro Quebec	Beauharnois Generating Station	Canada	Radial			1022 mm	40.24	Aug. 1988
US Bureau of Reclamation	Grand Coulee Dam	U.S.A.	Radial	Toshiba Turbine		792 mm	31.18	Mar. 1988
Meridian Energy	Manapouri Power Station	New Zealand	Radial			910 mm	35.83	Jan. 1982

REFERENCE STORIES

GREASE FREE THORPLAS® FOR KAPLAN RUNNER BLADE BUSHINGS

In April 2005, operators at Alabama Electric Cooperative's 3-MW Gantt hydroelectric plant on the Conecuh River in Alabama, U.S.A., decided to replace the four runner blade trunnion bushings in the vertical Kaplan turbine of Unit 4. The bushings reduce friction when the runner blade pitch varies according to head and flow.

The powerhouse originally contained three vertical Francis turbines. In 1984, Alabama Electric replaced Units 1 and 2 with a single 2-MW vertical Kaplan unit (Unit 4). Unit 3 remains in service.

For Unit 4, Alabama Electric selected a bushing manufactured by Thordon Bearings. The bushing is the company's new ThorPlas®, a grease and oil-free engineered (i.e., non-elastomer) thermoplastic bearing.

"We chose the Thordon bushing because we have been using a Thordon turbine main guide bearing without any problems since 1984," says Wes Thomasson, a mechanical engineer in the central generation section of Alabama Electric.

ThorPlas® is a crystalline, premium grade, homogeneous, engineered thermoplastic bushing that is self-lubricating and can accept operation pressures up to 31 MPa (4,500 psi) without the need for metal backing, says Ingrid A. Muschta, P.Eng., Product Manager for Thordon.

"ThorPlas® has demonstrated exceptional wear and abrasion resistance and has one of the lowest wear rates among nearly all rigid polymers," says Muschta. "Due to its ratio of static to dynamic co-efficient of friction, it does not exhibit any stick slip effect. Instead,

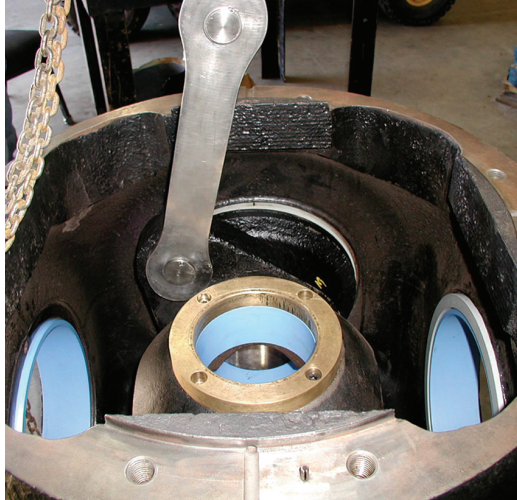

it provides a smooth, quiet, stable operation in demanding applications such as wicket gate trunnion bearings."

The material has good thermal stability (minimal to no changes due to temperature) and low water absorption (minimal to no changes due to exposure to water), which allow for tighter installed clearances, Muschta says. Furthermore, she says it is easy and safe to machine because it produces no hazardous dust and releases no dangerous byproducts.

Alabama Electric's Thomasson says the fact that the bearing is self-lubricating was the most important characteristic in its selection. "The runner location is not easily accessed," he says. "You have to stop the unit, put down headgates or stoplogs, dewater the pit, and climb in there. And even then it's still not easy to get to the bearings. It was not designed to be lubricated.

He also appreciates the environmentally friendly nature of ThorPlas®. "If you used one with grease and the seal failed, you could contaminate the stream," he says.

Thomasson cited ease of installation as another key factor in choosing the Thordon product. According to Muschta, the product is installed using a "freeze fit" or "shrink fit" method. "Due to its coefficient of thermal expansion, ThorPlas® will contract or shrink somewhat when cooled," she says. "You can then place the bearing into the housing by slipping it or lightly pressing it in."

Thomasson reports no problems so far. "The bushings are easy to work with," he says. "And in the year they have been in use at the plant, they have been trouble free." **Nw**

*"From Hydro Review, June 2006,
Copyright HCI Publications,
www.hcipub.com,
Excerpted with permission."*



Alabama Electric installed ThorPlas® runner blade trunnion bushings for their Kaplan turbine

REFERENCE STORIES

MAINTENANCE AT INCO GENERATING PLANT NO LONGER FRAZZLED BY DOWNTIME CONCERNS



Frazzle ice is created when long periods of extremely cold weather, typically in the -35°C range, turn river water into a giant Slushie®. This isn't uncommon on The Spanish River in Northern Ontario, Canada, home of three Inco Hydropower Generating Stations. Frazzle ice is a regular occurrence almost every spring, pounding into the intakes and causing pumps that provide water to the turbines to ice up and shut down.

"When this occurs," says Claude Mailloux, Planner/Supervisor for Inco, "there is a risk that the turbine may run dry." As a result, the main guide bearings may overheat and need to be removed, inspected and reinstalled again.

Easier said than done. Until, that is, Inco began to use Thordon SXL.

Powering A Century Of Growth

The Spanish Riverways has an important dual role in Northern Ontario. It is one of the most breathtaking recreational waterways in the Province, attracting tourists worldwide. It is also the source of hydroelectric power that fuels the region's vast pulp and paper and nickel mining industries. Inco taps this tributary with generating plants located in Big Eddy, High Falls and Nairn Falls.

For most of the operational history of these plants, wood called *lignum vitae* was used as the main guide bearing. But as the rare source of this hard and oily timber - the guayacum tree - became even rarer, Inco was forced to look for alternatives.

"They originally switched over to phenolic bearings," said Lorne Thornton, President of

Pioneer Power Industries, a long-time Thordon Bearings distributor, "But these came with maintenance headaches and other concerns."

The problem was, the river water contains a high level of particulates, making it abrasive. As a result, the phenolic bearings would wear rapidly and need to be changed approximately every two to three years. This was not a quick process. In fact, because of the hands-on lead chinking that was involved, the turnaround time to remove and install the bearings was up to four months.

"To make matters worse," says Thornton, "the phenolic bearings would constantly need adjusting to maintain performance, which only added to the workload and expense."

Clearly, Inco needed a better solution. And they found it, in Thordon SXL.

A Track Record That Speaks For Itself

Proven in demanding hydroelectric applications around the globe, Thordon SXL has become the industry standard. An elastomeric polymer, the bearing features grease-free operation, remarkably low wear and exceptional performance in dirty water conditions. It's the bearing of choice for water lubricated main shafts and pumps in both rehabilitation and new turbine projects.

"Inco not only wanted to lower maintenance costs, but they also wanted to eliminate lead chinking. Thordon SXL was the answer to both of these issues," says Thornton.

To reduce downtime in the future, Thornton and the engineers at Thordon Bearings recommended a stave configuration. This

helped reduce the time it would take to remove, service and reinstall the bearings from the current standard of three to four months to just a few days!

The new bearings were installed in Unit #3 (one of three turbines in total) at the Nairn Falls plant in 1999. After excellent performance over the next 24 months, SXL was installed in the other two units.

"So far, Thordon has lasted twice as long as the previous phenolic bearing," says Mailloux. "And the longer lifespan has kept labour and materials costs down while expanding uptime." Bearing performance is monitored continuously and has been running within acceptable parameters for more than five years. "This is remarkable considering the rough operating conditions and the fact that the turbines are nearly one hundred years old!"

Getting Frazzled Once Again

Then mother nature struck. In January 2004, frazzle ice once again formed on The Spanish River. During this inclement period, Unit #2 started and stopped five times, each time running dry. The fear was that the bearing would be burnt and require immediate changeout, something that would be expected from a phenolic material. It wasn't. In fact, after inspection, Thordon SXL was only mildly scuffed.

"And the good news is," says Thornton, "Inco's maintenance staff was able to clean the exfoliated material from the water grooves and reinstall the bearing in the same day."

This allowed Inco to keep this unit on line for the upcoming spring run-off period and have a planned outage in the summer for the changeout of the bearing during the low water flow period.



REFERENCE STORIES

THORDON SXL GUIDE BEARING ELIMINATES RISK AT THE STAR LAKE GENERATING STATION

Reliability was an important factor in the Star Lake Hydro Partnership's decision to replace the Star Lake Generating Station's turbine guide bearing. The 18-MW facility — owned by a partnership of Abitibi-Consolidated Inc. (51 percent) and Enel North America, Inc. (49 percent) — runs about 98 percent of the time, shutting down for scheduled maintenance for only six to seven days a year.

As manager of the Star Lake Generating Station in southwestern Newfoundland, Canada, Robert Conlon wanted to replace a water-lubricated, hydrostatic turbine guide bearing in a vertical Francis unit that required a complex high pressure filtered water supply. This filtration system was very costly to maintain and a previous hydrostatic bearing failure during initial startup had required the replacement of both the turbine shaft and the bearing, which meant a month-long and costly outage.

"The second water-lubricated, metal turbine guide bearing has performed fine for four years," says Conlon. "However, we were concerned of the consequences if this bearing failed at full load. The result could be an unexpected failure destroying the bearing, damaging the shaft and possibly damaging the generator."

Those fears were eliminated, however, when the hydrostatic metal bearing was replaced with a water-lubricated, Thordon SXL turbine guide bearing operating in hydrodynamic conditions.

For water lubricated metal bearings such as the one at Star Lake, the fluid film must be consistent between the shaft and the bearing. If abrasives are present in the lubricating water, the fluid film may be disrupted and the bearing will fail.

The water supplied to water lubricated metal bearings has to be extremely clean (contaminants removed to 25-30 microns).

Thordon SXL bearings allow a larger diametrical clearance between the shaft and the bearing surface and require more water than the metal bearing. The water flow requirements to the SXL bearing surface for cooling purposes are 0.15 litres/minute per mm (1 U.S. gallon/minute per inch) of shaft diameter



Thordon SXL Main Guide Bearing ready for installation at Star Lake

at standard clearances. However, the water filtering requirements are not as stringent for SXL bearings, because wear life is not seriously effected with water contaminants up to 150 to 200 microns.

Thordon SXL is an elastomeric polymer bearing material with a 25-year history of long-life performance in water lubricated main shaft guide bearings. "It was certainly the right choice for us," says Conlon. "Even if the Thordon SXL bearing were to fail, it would not fail suddenly and unexpectedly. The most that would happen is that the Thordon material would wear a little bit."

Before making the commitment to

purchase the Thordon SXL bearing, the Star Lake Hydro Partnership researched the product extensively. This included checking references in North America and Europe. "Satisfied with the experience of others," says Conlon, "the order was eventually placed for two bearings (one plus a spare) in July 2003".

Rapid installation reduces downtime

Normally, the turbine shaft has to be dismantled to install a solid journal bearing. Disassembly and re-assembly is an arduous process. In addition, the whole unit has to be realigned as a part of the process.

Working with Thordon's engineers, however, the decision was made to design and fabricate the bearing in two halves. "We simply took the two halves and bolted them together around the shaft," says Conlon. "Once the Thordon bearing was in place, it was positioned with a constant annulus around the shaft."

Before removing the old bearing, the turbine runner had been wedged in position so that the turbine shaft was centered on the old bearing. As a result, no time-consuming realignment was necessary.

The Thordon bearing was so simple to install, in fact, that the outage lasted just six days, which Conlon observed, "was a large saving in time and money."

Confident that the Thordon SXL bearing will not fail unexpectedly, the Star Lake Hydro Partnership is comfortable that they have made a major improvement in Station reliability. The Thordon SXL bearing is performing as anticipated. **Nw**

REFERENCE STORIES

THORSEALS AND HPSXL SOLVE WICKET GATE LEAKAGE PROBLEM

As any beaver will tell you, stemming the unrelenting force of river water is a complex engineering feat. So it's not surprising that the first dam to span the massive Columbia River in Washington State, U.S.A. - the *Rock Island Dam Hydroelectric Project* - would run into its share of leakage problems.

Operated by the Chelan County Public Utility District (PUD), the project has a history that dates back seventy-five years. Today, the dam consists of two powerhouses. The second, constructed during the late 1970s, features eight horizontal bulb turbines, each with 24

"Ultimately," says Breiwick, "we were awarded two consecutive contracts to build 24 new wicket gate housing assemblies with upgraded bearings and seals." These new units would serve as interchangeable spares, facilitating the upgrading of all the existing units over time.

Back in 1988, Thordon SXL Thor-Tape had been installed to address some original bearing problems. "This time around," says Breiwick, "we collaborated with Ken, and the application engineering specialists at Thordon, and it was decided that we needed a bearing that could be

drained and the volume tracked and evaluated. "Thordon designed and manufactured the second seal for us within a very short timeframe," says Anderson, "which I thought was extraordinary."

After the successful installation of the initial 24 wicket gate housings, *Pacific Marine Equipment* was eventually awarded the contract to overhaul all 192 existing units. They are managing the project, including production and assembly, while Thordon is providing the bearing and sealing elements, design and technical support. Five turbine units have



Rock Island Dam Hydroelectric Facility located on the Columbia River, Washington, USA

wicket gates. Collectively, these turbines produce 1.8 million megawatt hours of power annually.

Leakage began to occur in the wicket gates soon after the second powerhouse was put into commercial operation due to the original poor seal design. "This resulted in costly maintenance problems over the years," says PUD Project Engineer Ken Anderson. "Water ingress occurred directly into areas where electronic devices, sensors, and electrical equipment were located." A makeshift system of tarps was used to divert the water. Raincoats became a necessity.

When Anderson joined the project in 1999, solving this excessive leakage problem became his primary concern. He began the process by consulting Tom Breiwick of *Pacific Marine Equipment* of Seattle, a longtime Thordon distributor.

interference fit into the housing." This would tighten the dimension on the bearing bores, resulting in less play and damage to the seals.

The answer was HPSXL. This is the hardest and stiffest grade of Thordon, featuring the lowest coefficient of friction for less wear and elastomeric qualities for strong performance under edge loading conditions.

The seals selected for the job were Thorseals. These are Thordon's high performance line of tough, abrasive resistant hydraulic cylinder seals providing positive sealing over a wide range of operating pressures. "Due to all the previous sealing problems, I came up with a new double seal design to replace the single seal system," says Anderson. In the new design, the space between the first and second seal was plumbed so that, if leakage did occur, the water could be

been overhauled to date. The remaining three are due to be completed by May 2004.

The ultimate question is, of course, has the leakage stopped? "We were dealing with an infiltration rate of 20 gallons per minute on some units," says Anderson. "Today there's virtually no leakage at all from the new units we have installed. So, yes, finally the problem has been solved." 

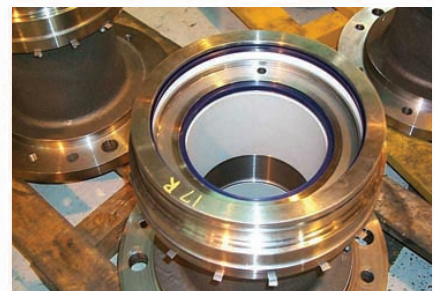

Thordon HPSXL wicket gate bearings with Thorseals

REFERENCE STORIES

THORDON IMPROVES HYDROELECTRIC EFFECIENCIES...

Thordon non-metallic bearings are the recognized choice of hydroelectric power producers for long life, low friction bearing systems. These pollution-free bearings function well whether sealed and dry or immersed in water.

A testament to the durability and flexibility of Thordon bearings in hydroelectric applications is Mercer Construction Company, Inc. (MCC), an operations and maintenance company that does extensive municipal and third-party work. Since 1991, MCC has installed five Thordon bearings at hydroelectric plants throughout upstate New York.

"We have a consistent operating history with Thordon," says MCC's president, Dave Crandell. "We just hadn't gotten the service life we wanted out of the rubber turbine marine bearings that we were using. The Thordon bearings have reduced

our downtime and operating costs."

MCC has teamed up with Thordon Distributor Johnson Packings, to install Thordon bearings with shaft diameters ranging from 355mm to 900mm (14" to 36") and lengths up to 1820mm (72"), in both horizontal and vertical applications.

A Thordon main guide bearing that was installed at Fourth Branch on the Mohawk River in 1991 performs as well today as it did nearly 10 years ago. In this horizontal application, it is important to maintain a water film in uniform surface contact, and rubber bearings that were formerly used wore out in three to four years. Crandell reports that the more durable Thordon bearing has already proven to last three times as long as any rubber bearing. In another application, a Thordon bearing has held up for more than seven years, while the grease-lubricated Babbitt bearings that were

formerly used only lasted about a year and a half each.

"With Thordon, we got a much longer service life and extended our dewatering schedule from one to three years," Crandell said. "These bearings are just more reliable." 

Thordon SXL Main Guide Bearing



THORDON

Hydro Turbine - Water Lubricated Main Guide Bearings

Thordon Grade	Company	Power/Dam Station Owner	Power/Dam Station	Country	Max. Head (M)	Shaft Diameter (mm)	Type of Turbine	Direction	MW	Initial Installation Date
SXL	LMZ	EuroSibEnerg	Krasnoyarskaya	Russia	124	2,390	Francis	Vertical	500	Jun -2001
SXL	LMZ	EuroSibEnerg	Krasnoyarskaya	Russia	124	2,390	Francis	Vertical	500	Jul -2002
SXL	LMZ	EuroSibEnerg	Krasnoyarskaya	Russia	124	2,390	Francis	Vertical	500	Aug -2003
SXL	LMZ	EuroSibEnerg	Krasnoyarskaya	Russia	124	2,390	Francis	Vertical	500	Jun -2006
SXL	LMZ	EuroSibEnerg	Krasnoyarskaya	Russia	124	2,390	Francis	Vertical	500	Jun -2005
SXL	LMZ	RusHydro	Sayano-Shushenskaya	Russia	194	1,970	Francis	Vertical	640	Jan -2001
SXL	LMZ	RusHydro	Volzhszkaya	Russia	44	1,520	Kaplan	Vertical	125	Sep -2004
SXL	LMZ	RusHydro	Volzhszkaya	Russia	44	1,520	Kaplan	Vertical	125	Mar -2004
SXL	LMZ	RusHydro	Zeiskaya	Russia	80	1,420	Kaplan	Vertical	225	Apr -2004
SXL	LMZ	RusHydro	Kolymyskaya	Russia	100	1,420	Kaplan	Vertical	180	Nov -2004
SXL		Northeast China Power Group	Fengman Power Station	China	91	970	Francis	Vertical	100	Jul -2003
GM2401	LMZ	Lenenergo	Narva Hydro Power Station	Russia	18	955	Kaplan	Vertical	40	Jun -2000
GM2401	LMZ	Lenenergo	Narva Hydro Power Station	Russia	18	955	Kaplan	Vertical	40	Jul -2001

Hydro Turbine - Water Lubricated Main Guide Bearings

Thordon Grade	Company	Power/Dam Station Owner	Power/Dam Station	Country	Max. Head (M)	Shaft Diameter (mm)	Type of Turbine	Direction	MW	Initial Installation Date
GM2401	LMZ	Lenenergo	Narva Hydro Power Station	Russia	18	955	Kaplan	Vertical	40	Mar -2002
SXL	LMZ	Kaztsink	Bukhtarma Hydro	Kazakhstan	90	920	Francis	Vertical	75	May -2004
SXL	LMZ	Kaztsink	Bukhtarma Hydro	Kazakhstan	90	920	Francis	Vertical	75	Aug -2001
SXL	LMZ	Kaztsink	Bukhtarma Hydro	Kazakhstan	90	920	Francis	Vertical	75	Feb -2003
SXL	LMZ	Kaztsink	Bukhtarma Hydro	Kazakhstan	90	920	Francis	Vertical	75	Jun -2005
SXL	LMZ	Kaztsink	Bukhtarma Hydro	Kazakhstan	90	920	Francis	Vertical	75	Nov -2006
SXL	LMZ	Kaztsink	Bukhtarma Hydro	Kazakhstan	90	920	Francis	Vertical	75	Sep -1999
SXL	LMZ	Kaztsink	Bukhtarma Hydro	Kazakhstan	90	920	Francis	Vertical	75	Aug -2002
GM2401	Mercer Management	Northbrook Energy, Inc.	Glen Park Hydro Power Plant	U.S.A.		864		Vertical	33	Jul -1996
GM2401	Mercer Management	Fort Miller Associates	Fort Miller Hydroelectric Plant	U.S.A.		864		Vertical	3	Jul -2003
GM2401	Cottrell Paper Mill			U.S.A.		851		Vertical		Apr -2001
SXL		Tulomakaya	Tulomakaya	Russia		850		Vertical	80	Mar -2004
SXL	LMZ	TGC-1	Belomorskaya	Russia	14	850		Vertical		Jan -2001

Hydro Turbine - Water Lubricated Main Guide Bearings

Thordon Grade	Company	Power/Dam Station Owner	Power/Dam Station	Country	Max. Head (M)	Shaft Diameter (mm)	Type of Turbine	Direction	MW	Initial Installation Date
SXL	Alabama Power	Alabama Power	H. Neely Henry	U.S.A.	32	838	Francis	Vertical	73	May-2004
SXL	American Hydro	Alabama Power	H. Neely Henry	U.S.A.	32	838	Francis	Vertical	73	Jul-1996
SXL	Waplans Mek Verkstad	E. on	Storfinnforsen G3	Sweden	50	825	Francis	Vertical	37	Sep-2002
SXL	LMZ	TGC-1	NIVA-3	Russia	78	800	Francis	Vertical	44	Jan-2004
GMZ401	Uzbekenergo	Uzbekenergo	Tyuyamuyunskaya	Russia	24	770	Kaplan	Vertical		Jan-2002
SXL	Firestone Natural Rubber	Firestone Plantations Company	Firestone Hydroelectric Power	Liberia		762		Vertical	5	Jul-2012
SXL	BC Hydro	BC Hydro	Ruskin Generating Station	Canada	59	749	Francis	Vertical	35	Aug-2010
SXL	PGE Energia	PGE Energia	Dychow Hydro Plant	Poland	28	740	Kaplan	Vertical	30	May-2013
SXL	PGE Energia	PGE Energia	Dychow Hydro Plant	Poland	28	740	Kaplan	Vertical	30	Sep-2012
SXL	PGE Energia	PGE Energia	Dychow Hydro Plant	Poland	28	740	Kaplan	Vertical	30	Nov-2004
SXL	LMZ	LMZ	Buchtarminskaya	Russia	70	720	Francis	Vertical	77	Jan-1998
SXL	LMZ	LMZ	Buchtarminskaya	Russia	70	720	Francis	Vertical	77	Jan-2002
SXL	LMZ	RusHydro	Zaramagskaya Power Station	Russia		720				Nov-2004

Hydro Turbine - Water Lubricated Main Guide Bearings

Thordon Grade	Company	Power/Dam Station Owner	Power/Dam Station	Country	Max. Head (M)	Shaft Diameter (mm)	Type of Turbine	Direction	MW	Initial Installation Date
HPSXL	LMZ	TGC-1	NIVA	Russia	78	665	Francis	Vertical	44	Jan -2005
HPSXL	LMZ	TGC-1	NIVA	Russia	78	665	Francis	Vertical	44	Sep -2006
HPSXL	LMZ	TGC-1	NIVA	Russia	78	665	Francis	Vertical	44	Sep -2005
HPSXL	LMZ	TGC-1	NIVA	Russia	78	665	Francis	Vertical	44	Jan -2006
SXL	Hydroelectrica	Ramnicu Valcea	Malaita Power Plant	Romania		646	Kaplan	Vertical	9	Feb -2009
SXL	American Hydro		Boise Cascade, USA	U.S.A.		635	Kaplan	Horizontal		Jul -1990
COMPAC	Andritz	TransAlta Corp.	Taylor	Canada		631	Kaplan	Horizontal	14	May -2007
SXL	American Hydro	Avista	Avista	U.S.A.		628	Kaplan	Horizontal		Jul -1993
SXL	Rochester Gas & Electric		Station 5	U.S.A.	43	622	Kaplan	Vertical	15	Jul -1994
SXL	Yushkozerskaya	TGC1	Yushkozerskaya	Russia	12	620	Kaplan	Vertical	9	Jul -2002
XL		Telasi JSC	Khrami Power Plant	Georgia		615	Francis	Vertical	55	Jan -2007
SXL	KTZ		Mamakanskaya	Russia		615	Francis	Vertical	22	Jan -2000
SXL	KTZ		Mamakanskaya	Russia		615	Francis	Vertical	22	Jan -2001

Hydro Turbine - Water Lubricated Main Guide Bearings

Thordon Grade	Company	Power/Dam Station Owner	Power/Dam Station	Country	Max. Head (M)	Shaft Diameter (mm)	Type of Turbine	Direction	MW	Initial Installation Date
SXL	Wisconsin Power Station	Wisconsin Public Service Corp	Merrill #3	U.S.A.		610		Horizontal		Jul -1987
SXL	American Hydro	Alcoa	Yadkin Narrows	U.S.A.	65	584	Francis	Vertical	27	Jul -1992
SXL	Talleres J. Vila	Confederación Hidrográfica	Calaspara Dam	Spain		580				Oct -2012
SXL	Hydro Quebec	Hydro Quebec	Rivière-des-Prairies Generating Station	Canada	9	577		Vertical	8	Sep -2011
SXL	Waplans Mek. Verkstad AB	Waplans Mek. Verkstad	Rotnen	Sweden		570		Vertical		Jul -1998
SXL	Voith Hydro	Endesa	Central Hidraulica de Lleida	Spain	27	560	Kaplan	Vertical	12	Nov -2010
SXL	Voith	Endesa	Central Hidraulica de Lleida	Spain	27	560	Kaplan	Vertical	12	Sep -2011
SXL	Litostroj	Hydro Quebec	Chute Allard	Canada	21	550	Saxo	Vertical	64	Jul -2008
SXL	Litostroj	Hydro Quebec	Rapides des Coeurs	Canada	25	550	Saxo	Vertical	82	Aug -2008
SXL	Litostroj	Hydro Quebec	Magpie River	Canada	23	550	Saxo	Vertical	39	Jun -2007
SXL	Enel North America	Enel North America	Star Lake	Canada	135	550	Francis	Vertical	18	Oct -2003
XL	LMZ	Sak Energomash	Zhinvali Power Plant	Georgia	100	520	Francis	Vertical	65	Jan -2008
SXL	Enel North America	Littleville Power Company	Crescent Hydroelectric	U.S.A.	10	508	Kaplan	Vertical	2	Jul -2006

Hydro Turbine - Water Lubricated Main Guide Bearings

Thordon Grade	Company	Power/Dam Station Owner	Power/Dam Station	Country	Max. Head (M)	Shaft Diameter (mm)	Type of Turbine	Direction	MW	Initial Installation Date
SXL	Statkraft	Tranyds	Tranyd	Sweden	20	501	Kaplan	Vertical	14	Aug -2009
SXL	Statkraft	Tranyds	Tranyd	Sweden	20	501	Kaplan	Vertical	14	Jul -2003
SXL	TURAB	TURAB	Harjevad	Sweden		500		Vertical		Aug -2004
SXL	Energopro Georgia	Energopro Georgia	Gumati Hydro Power Plant	Georgia	30	500	Kaplan	Vertical	67	Mar -2009
SXL	Algonquin Power		Glenn Falls, Unit G2	U.S.A.		494		Vertical		Jan -2003
SXL	Voith Hydro	Skagerak Kraft	Gronvollfoss Power Plant	Norway	22	490	Kaplan	Vertical	26	Nov -2009
SXL	Litostroj	TransCanada Corp.	Vernon	U.S.A.	11	480	Kaplan	Vertical	37	May -2007
SXL	Litostroj	Ontario Power Generation	Sandy Falls	Canada	9	480	Saxo	Vertical	5	Jan -2010
SXL	Litostroj	Ontario Power Generation	Hound Chute	Canada	12	480	Saxo	Vertical	10	Jan -2010
SXL	Litostroj	Ontario Power Generation	Lower Sturgeon Falls	Canada	13	480	Saxo	Vertical	14	Jan -2010
SXL	Litostroj	Hydro Quebec	Pont Arnaud	Canada	16	480	Saxo	Vertical		Jan -2010
SXL	Litostroj	Hydro Quebec	Chut Garneau	Canada	10	480	Saxo	Vertical	8	Jan -2010
SXL	Central Maine Power	EDF Energy	West Buxton	U.S.A.		476		Vertical		Jul -1990

Hydro Turbine - Water Lubricated Main Guide Bearings

Thordon Grade	Company	Power/Dam Station Owner	Power/Dam Station	Country	Max. Head (M)	Shaft Diameter (mm)	Type of Turbine	Direction	MW	Initial Installation Date
SXL		Hydroelectrica	Govora Power Station	Romania		465			200	Jun-2005
SXL	Vale Inco	Vale	High Falls #6	Canada		463		Horizontal	2	Jul-2006
SXL		Statkraft Energy	Gidbole	Sweden		461				Nov-2013
SXL		Statkraft Energy	Gidea	Sweden		461				Nov-2013
SXL	Graningeverken	Graningeverken	Gidbole	Sweden		460		Vertical		Jul-1997
SXL	Graningeverken	Graningeverken	Bjorna	Sweden		460		Vertical		Jul-1998
SXL	Graningeverken	Graningeverken	Gidea	Sweden		460		Vertical		Jul-1997
SXL	Duke Energy		Cedar Creek	U.S.A.		457		Vertical		May-2002
SXL	CHI Energy	Enel	Weeks Falls	U.S.A.		457		Vertical		Sep-2002
SXL	Twin Falls Hydro Company	ENEL North America	Twin Falls Hydro	U.S.A.	152	457	Francis	Horizontal	24	Apr-2011
SXL	L.A. Dept. of Water & Power	L.A. Dept. of Water & Power	San Francisco Powerplant	U.S.A.		445		Vertical		Jul-1991
SXL	Orion Power-Glens	TransCanada Corp.	Sherman #1	U.S.A.		445		Vertical	6	Jul-1996
SXL	Boom Hydro Energy	Boom Hydro Energy	Ulankal Hydro Power Station	India		440				Apr-2012

ThorPlas-Blue Wicket Gate and Operating Mechanism Bearing References

Company	Power/Dam Station Owner	Power/Dam Station	Country	Max. Head (M)	Shaft Diameter (mm)	Type of Turbine	Direction	MW	Initial Installation Date
Dongfang Electrical		Manwan	China		340	Francis		250	Feb -2006
	Dongfang Electric	Huangjiping Power Station	China	95	320	Francis	Vertical	200	Apr -2014
Seattle City Light	Seattle City Light	Boundary Hydroelectric Plant	U.S.A.		296	Francis	Vertical	1050	Dec -2010
	Seattle City Light	Boundary Hydro Electric Plant	U.S.A.		296				Dec -2010
Alabama Electric		Gantt Hydro, No. 4	U.S.A.		282	Kaplan		3	Sep -2004
Endesa	Endesa	Pangué	Chile	99	280	Francis	Vertical	460	Mar -2008
Harbin Electric Machinery Co.		Baishan Hydro Plant	China	110	270	Francis		1800	Jul -2005
	Public Power Corporation	Thisavros Hydro Plant	Greece		240	Francis		384	Sep -2012
Xcel Energy		Chippewa Falls	U.S.A.		229				Mar -2006
Xcel Energy			U.S.A.		229				Mar -2006
	Fortum Power	Seitenoikea	Finland	35	220				Sep -2008
SMUD	SMUD	Camino	U.S.A.	40	213	Francis	Vertical	154	Oct -2010
	Dongfang Electric Machinery	Mamaya Power	China		210	Francis		190	Apr -2013

ThorPlas-Blue Wicket Gate and Operating Mechanism Bearing References

Company	Power/Dam Station Owner	Power/Dam Station	Country	Max. Head (M)	Shaft Diameter (mm)	Type of Turbine	Direction	MW	Initial Installation Date
	Meridian Energy	Ohau A Power Station	New Zealand	200	200			264	Jun -2014
Hydroserv Bistrita	Hydroelectrica	SH Bistrita	Romania	190	190				Feb -2015
	Hydroelectricia	Ramnicu Valcea Powerplant	Romania	180	180				May -2014
	Meridian Energy	Ohau A Power Station	New Zealand	180	180			264	Sep -2012
	Meridian Energy	Manapouri Power Station	New Zealand	180	180	Francis	Vertical	850	Aug -2012
Hydroserv	Hydroelectrica	Dragasani Power Plant	Romania	180	180	Kaplan		5	Dec -2014
	Statkraft Sweden AB	Bjurfors Lower	Sweden	173	173		Vertical	78	Apr -2014
Pacific Gas & Electric		Butt Valley	U.S.A.	28	172			40	Feb -2007
GE Hydro	GE Hydro		Sweden	170	170				Dec -2007
	Bistrita	Vaduri Power Station	Romania	170	170	Kaplan		22	Feb -2010
Harbin Electric Machinery Co.		Malutangli	China	380	160	Francis		135	Mar -2008
	Harbin Electric	Puxiqiao Power Plant	China	109	160	Francis	Vertical	100	May -2014
Perepadnaya-1 Hydro		Perepadnaya Hydro Station	Georgia	150	150		Vertical	73	Dec -2008

Radial and Axial Segmented Shaft Seal References

Grade	Company	Power/Dam Station Owner	Power/Dam Station	Country	Max. Head (M)	Shaft Diameter (mm)	Type of Turbine	Direction	MW	Initial Installation Date
SXL	Itaipu Binacional	Itaipu	Itaipu Hydroelectric Power Plant	Brazil	118	3,770	Francis	Vertical	700	Oct -2005
SXL	Itaipu Binacional	Itaipu	Itaipu Hydroelectric Power Plant	Brazil	118	3,770	Francis	Vertical	700	Jun -2014
SXL	Harbin Electric Machinery	Ertan Hydropower Development Co.	Ertan Power Station	China	189	2,380	Francis	Vertical	550	Nov -2004
HPSXL	IMPESA Hydro	IMPESA		Argentina		2,044				Mar -2001
HPSXL	IMPESA Hydro	IMPESA		Argentina		1,925				Mar -2001
SXL	Harbin Electric Machinery	Harbin Electric Machinery	Gongboxia Power Station	China	142	1,820	Francis	Vertical	300	Feb -2003
SXL	Voith Hydro	Vattenfall	Akkats Power Plant	Sweden	46	1,600	Kaplan	Vertical	75	Aug -2011
SXL	Harbin Electric Machinery	Wuling Electric Power	Sanbanxi Power Plant	China	185	1,530	Francis	Vertical	250	Aug -2005
SXL	Harbin Electric Machinery	Jiangxi Electric Power	Zhelin Power Plant	China	64	1,526	Francis	Vertical	120	Jan -2001
SXL	Harbin Electric Machinery		Kalun III	China		1,520		Vertical		May -2002
SXL	IMPESA	EPM Group	Porce III	Colombia	151	1,500	Francis	Vertical	172	Jun -2014
SXL	IMPESA	EPM Group	Porce III	Colombia	151	1,500	Francis	Vertical	172	Aug -2011
SXL	Masjed Suleiman Hydro Electric Power	IWPC	Masjed-e-Soleiman	Iran	180	1,400	Francis	Vertical	250	Apr -2012

Radial and Axial Segmented Shaft Seal References

Grade	Company	Power/Dam Station Owner	Power/Dam Station	Country	Max. Head (M)	Shaft		Direction	MW	Initial Installation Date
						Diameter (mm)	Type of Turbine			
SXL	Harbin Electric Machinery	Datang Lixianjiang Hydropower	Gelantan Power Station	China	113	1,395	Francis	Vertical	120	Apr -2006
SXL	Jupia Generating Station	CESP	Souza Dias (Jupia) Power Station	Brazil	43	1,300	Kaplan	Vertical	110	Jun -2011
SXL	Karkheh Power Plant	Khuzestan Regional Electric Power	Karkheh Power Plant	Iran	127	1,265	Francis	Vertical	140	Dec -2011
SXL	Harbin Electric Machinery	Harbin Electric	Jupudu Power Plant	China		1,210		Vertical		Apr -2006
SXL	Karkheh Power Plant	Khuzestan Regional Electric Power	Karkheh Power Plant	Iran	127	1,200	Francis	Vertical	140	Apr -2004
SXL	Harbin Electric Machinery	Harbin Electric	Nirji Power Plant	China	22	1,170	Francis	Vertical		Jun -2004
SXL	Dongfang Electrical Machinery	Ethiopian Electric Power Corp	Tekeze Hydropower Plant	Ethiopia	185	1,160	Francis	Horizontal	75	Jan -2006
SXL	Harbin Electric Machinery	China Yangtze Power Co.	Gezhouba Power Plant	China	47	1,130	Kaplan	Vertical	125	Apr -2006
SXL	Drakensberg Power Station	Eskom Generation	Drakensberg Pumped Storage	South Africa	156	1,100	Pump Turbine	Vertical	250	May -2011
SXL	Harbin Electric Machinery	Harbin Electric	Xishan Power Plant	China		1,070		Vertical		Sep -2006
SXL	Central Arizona Water Conservation	US Bureau of Reclamation	Mark Wilmer Pumping Station	U.S.A.	89	1,067	Pump Turbine		45	Jul -1995
SXL	Nagarjuna Sagar Generating Plant	APGENCO	Nagarjuna Sagar Generating Plant	India	150	1,050	Francis	Vertical	100	Dec -2011
SXL	Hydro Quebec	Hydro Quebec	Beauharnois Generation Station	Canada	21	1,022	Kaplan	Vertical	45	Aug -1988

Radial and Axial Segmented Shaft Seal References

Grade	Company	Power/Dam Station Owner	Power/Dam Station	Country	Max. Head (M)	Shaft Diameter (mm)	Type of Turbine	Direction	MW	Initial Installation Date
SXL	Harbin Electric Machinery	Northeast China Electric Power	Baishan Power Plant	China	105	1,015	Pump Turbine	Vertical	150	Aug -2005
SXL	Harbin Electric Machinery	Qinghai Hydropower Group	Kangyang Power Station	China	36	970	Bulb	Vertical	41	Aug -2005
SXL	Harbin Electric Machinery	Qinghai Hydropower Group	Fengman Power Station	China	69	970	Francis	Vertical	60	Aug -2003
HPSXL	IMPESA Hydro			Argentina		970				Sep -2001
SXL	California Department of	U.S. Bureau of Reclamation	San Luis Dam	U.S.A.	93	940	Francis	Vertical	53	Mar -2003
SXL	Meridan Energy	Meridan Energy	Manapouri Power Station	New Zealand	178	910	Francis	Vertical	121	Jan -1982
SXL	Hidroelectrica	Hidroelectrica	Dragasani Power Plant	Romania		910	Kaplan		5	Dec -2014
SXL	Harbin Electric Machinery	Harbin Electric	Banglang Power Plant	China	130	892	Francis	Vertical		May -2002
SXL	Dongfang Electric Machinery	Datang International Power Generation	Nalan Power Plant	China		892	Francis	Vertical	50	Oct -2005
SXL	Harbin Electric Machinery	Harbin Electric	Three Gorges (Sanxia) Power	China	80	892	Francis	Vertical	50	Nov -2001
SXL	CEZ Group	Turnu Hydropower Plant	Turnu Hydro Power Plant	Romania		850	Kaplan	Vertical	35	Sep -2006
SXL	Khrami GES-2 Hydro Power Plant	Telasi JSC	Khrami II Power Station	Georgia		840	Francis	Vertical	55	Jun -2011
SXL	Dongfang Electric Machinery	Dongfang Electric	Aoluke Power Plant	China		835		Vertical		Nov -2006

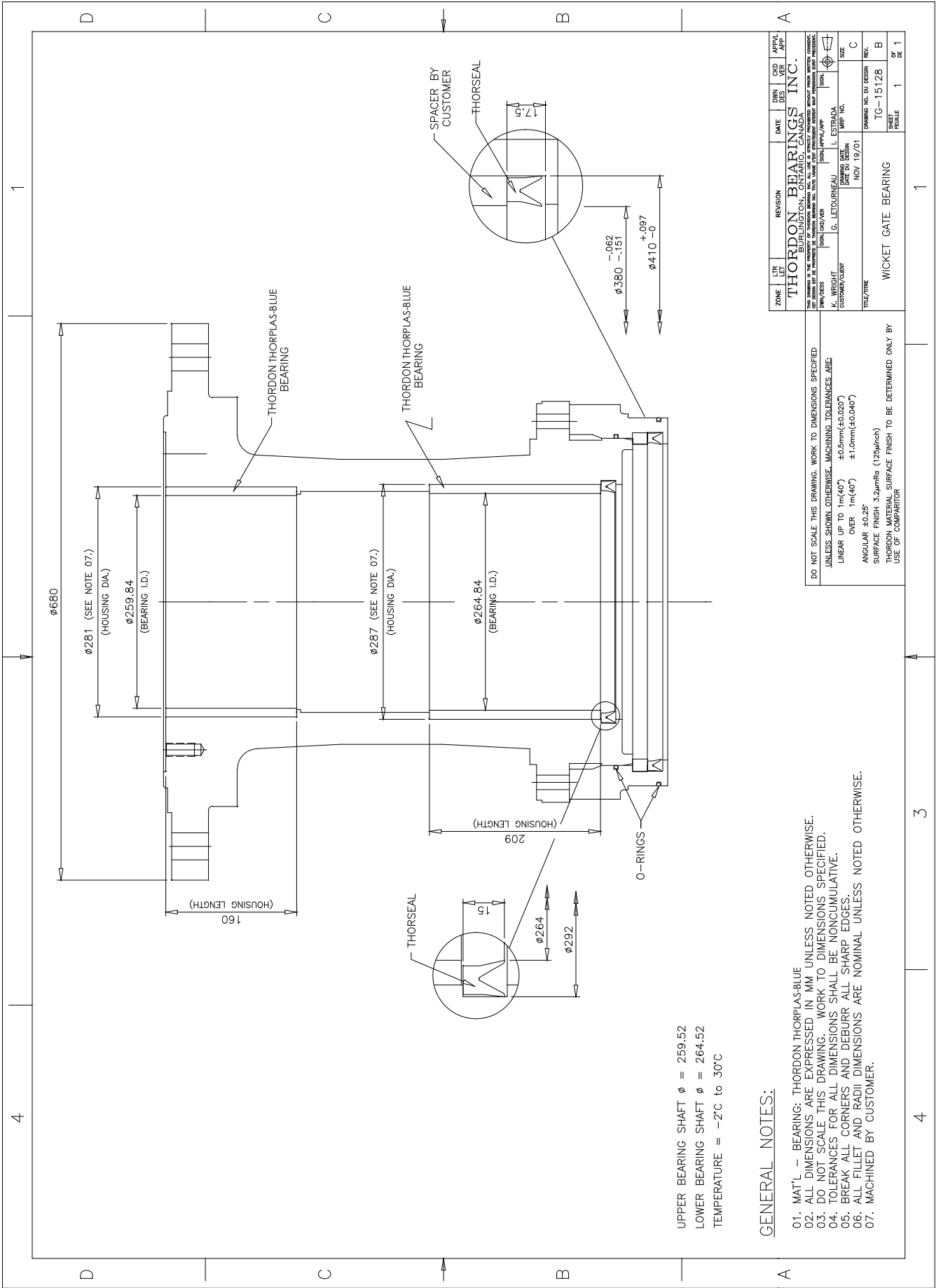

UPPER BEARING SHAFT ϕ = 259.52
 LOWER BEARING SHAFT ϕ = 264.52
 TEMPERATURE = -2°C to 30°C

GENERAL NOTES:

- 01. MAT'L - BEARING: THORDON THORPLAS-BLUE
- 02. ALL DIMENSIONS ARE EXPRESSED IN MM UNLESS NOTED OTHERWISE.
- 03. DO NOT SCALE THIS DRAWING. WORK TO DIMENSIONS SPECIFIED.
- 04. TOLERANCES FOR ALL DIMENSIONS SHALL BE NONCUMULATIVE.
- 05. BREAK ALL CORNERS AND DEBURR ALL SHARP EDGES.
- 06. ALL FILLET AND RADIUS DIMENSIONS ARE NOMINAL UNLESS NOTED OTHERWISE.
- 07. MACHINED BY CUSTOMER.

DO NOT SCALE THIS DRAWING. WORK TO DIMENSIONS SPECIFIED
 UNLESS SHOWN OTHERWISE. MACHINING TOLERANCES ARE:
 LINEAR UP TO 1m(40") $\pm 0.5mm(\pm 0.020")$
 OVER 1m(40") $\pm 1.0mm(\pm 0.040")$
 ANGULAR $\pm 0.25'$
 SURFACE FINISH 3.2 μmRa (125 $\mu inch$)
 THORDON MATERIAL SURFACE FINISH TO BE DETERMINED ONLY BY
 USE OF COMPARTOR

ZONE	LET	REVISION	DATE	DWGN	DES	CHK	APP'D
THORDON BEARINGS INC.							
<small>THIS DRAWING IS THE PROPERTY OF THORDON BEARINGS INC. ALL RIGHTS ARE RESERVED WITHOUT ANY WARRANTY OF ANY KIND. NO PART OF THIS DRAWING IS TO BE REPRODUCED OR TRANSMITTED IN ANY FORM OR BY ANY MEANS, ELECTRONIC OR MECHANICAL, INCLUDING PHOTOCOPYING, RECORDING, OR BY ANY INFORMATION STORAGE AND RETRIEVAL SYSTEM.</small>							
DW/ISS	THOR/CHK/VER	THOR/CHK/VER	G. LETOURNEAU	L. ESTRADA	THOR/APP/APP	THOR/APP/APP	THOR/APP/APP
CUSTOMER/CLIENT	K. WRIGHT	DRAWING DATE	NOV. 19/01	MFP NO.		SIZE	C
TITLE/TITLE	WICKET GATE BEARING		DRAWING NO. OR DESGN. NO.	TO-15128	REV.	SHEET	B
						OF 1	1

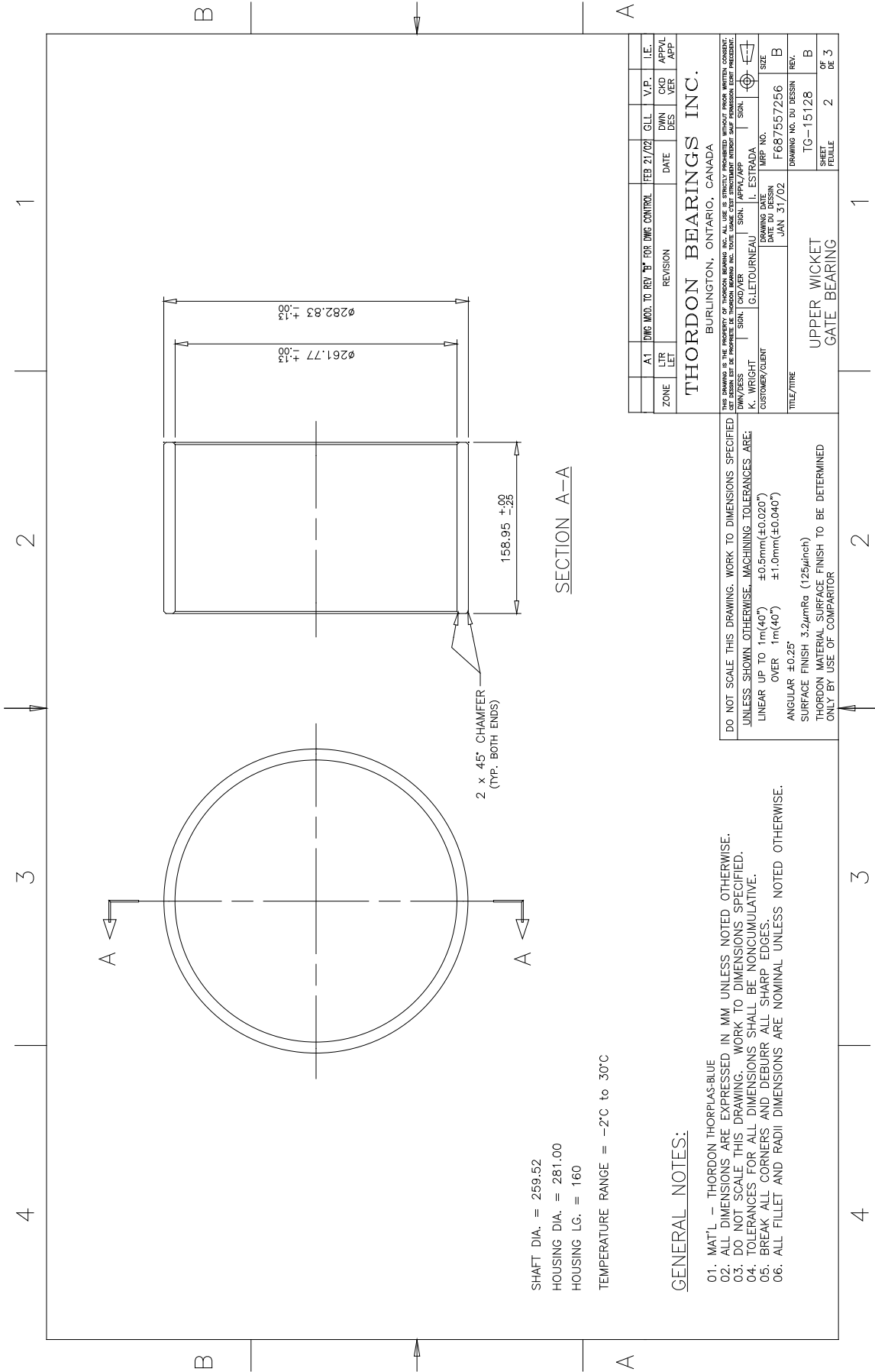

SHAFT DIA. = 259.52
 HOUSING DIA. = 281.00
 HOUSING LG. = 160

TEMPERATURE RANGE = -2°C to 30°C

GENERAL NOTES:

- 01. MAT'L - THORDON THORPLAS-BLUE
- 02. ALL DIMENSIONS ARE EXPRESSED IN MM UNLESS NOTED OTHERWISE.
- 03. DO NOT SCALE THIS DRAWING. WORK TO DIMENSIONS SPECIFIED.
- 04. TOLERANCES FOR ALL DIMENSIONS SHALL BE NONCUMULATIVE.
- 05. BREAK ALL CORNERS AND DEBURR ALL SHARP EDGES.
- 06. ALL FILLET AND RADIUS DIMENSIONS ARE NOMINAL UNLESS NOTED OTHERWISE.

SECTION A-A

2 x 45° CHAMFER
 (TYP. BOTH ENDS)

ZONE	A1	DWG. MOD. TO REV. BY	FOR DWG. CONTROL	DATE	FEB 21/02	GLL	V.P.	I.E.
LTR	LET	REVISION				DWN	CKD	APPVAL
						DSS	VER	APP
THORDON BEARINGS INC.								
BURLINGTON, ONTARIO, CANADA								
THIS DRAWING IS THE PROPERTY OF THORDON BEARINGS INC. ALL USE IS STRICTLY PROHIBITED WITHOUT PRIOR WRITTEN CONSENT.								
DWG/DESS	DRG/DES	DRG/DES	DRG/DES	DRG/DES	DRG/DES	DRG/DES	DRG/DES	DRG/DES
K. WRIGHT	G. LE TOURNEAU	I. ESTRADA						
CUSTOMER/CLIENT	DRAWING DATE	MRP NO.						
	JAN 31/02	F687557256						
TITLE/TYPE	DRAWING NO. / DU / REVISION		REV.					
	UPPER WICKET GATE BEARING		TG-15128					
			SHEET	2				
			FOUILLE	2				
								OF 3
								DE 3

DO NOT SCALE THIS DRAWING. WORK TO DIMENSIONS SPECIFIED UNLESS SHOWN OTHERWISE. MACHINING TOLERANCES ARE:
 LINEAR UP TO 1m(40") ±0.5mm(±0.020")
 OVER 1m(40") ±1.0mm(±0.040")
 ANGULAR ±0.25°
 SURFACE FINISH 3.2µmRa (125µinRt)
 THORDON MATERIAL SURFACE FINISH TO BE DETERMINED ONLY BY USE OF COMPARTOR

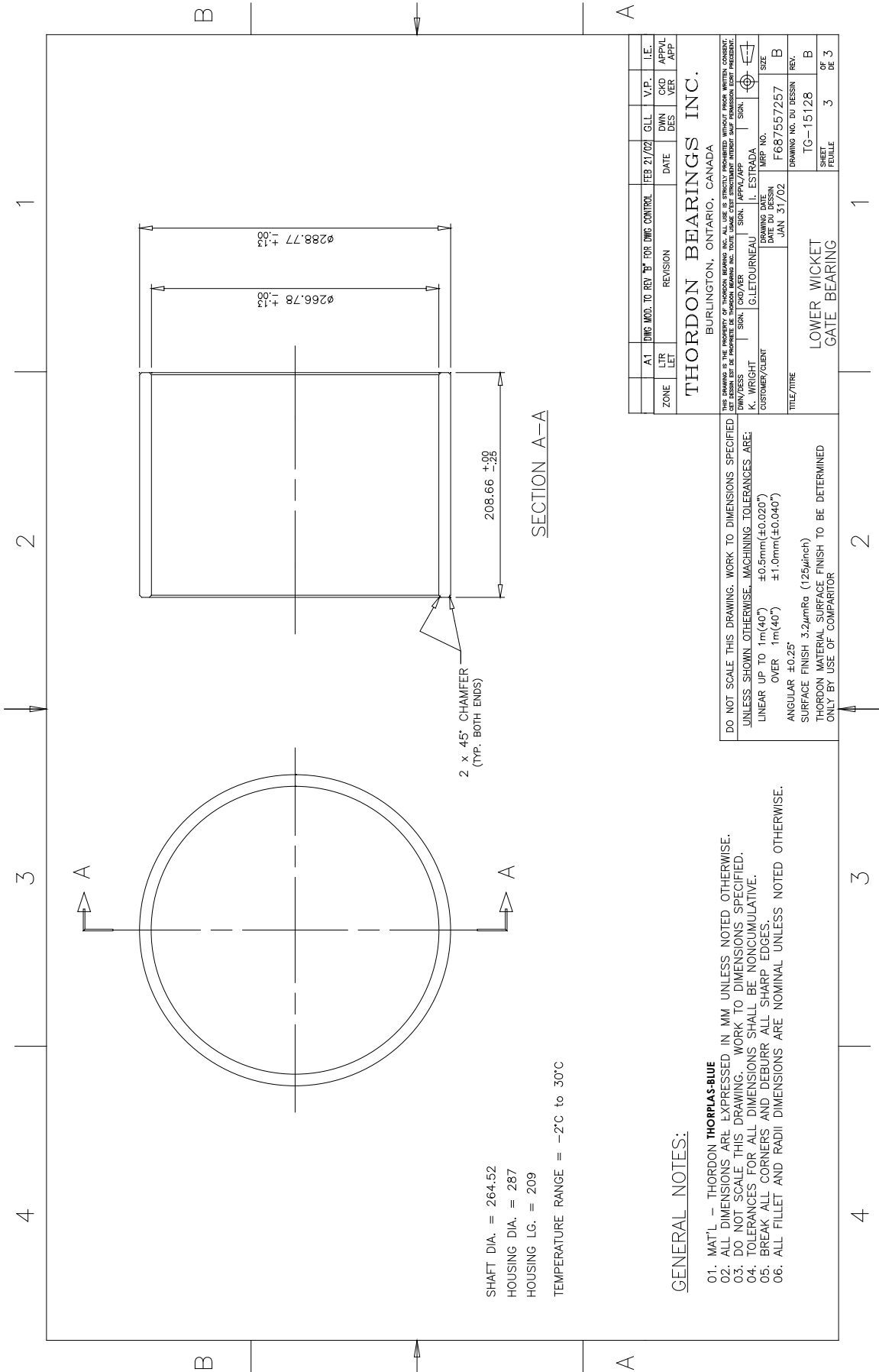

SHAFT DIA. = 264.52
 HOUSING DIA. = 287
 HOUSING LG. = 209

TEMPERATURE RANGE = -2°C to 30°C

GENERAL NOTES:

01. MAT'L - THORDON THORPIAS-BLUE
02. ALL DIMENSIONS ARE EXPRESSED IN MM UNLESS NOTED OTHERWISE.
03. DO NOT SCALE THIS DRAWING. WORK TO DIMENSIONS SPECIFIED.
04. TOLERANCES FOR ALL DIMENSIONS SHALL BE NONCUMULATIVE.
05. BREAK ALL CORNERS AND DEBURR ALL SHARP EDGES.
06. ALL FILLET AND RADII DIMENSIONS ARE NOMINAL UNLESS NOTED OTHERWISE.

DO NOT SCALE THIS DRAWING. WORK TO DIMENSIONS SPECIFIED UNLESS SHOWN OTHERWISE. MACHINING TOLERANCES ARE:
 LINEAR UP TO 1m(40") ±0.5mm(±0.020")
 OVER 1m(40") ±1.0mm(±0.040")
 ANGULAR ±0.25"
 SURFACE FINISH 3.2µmRa (125µinRa)
 THORDON MATERIAL SURFACE FINISH TO BE DETERMINED ONLY BY USE OF COMPARIOR

ZONE	A1	DWG. MOD. TO REV. BY FOR DWG. CONTROL	FEB 21/02	DATE	Q.L.L.	V.P.	I.E.
LET	LTR	REVISION		DATE	D.W.N.	C.M.D.	A.P.P.L.
					DES	VER	APP
THORDON BEARINGS INC.							
BURLINGTON, ONTARIO, CANADA							
<small>THIS DRAWING IS THE PROPERTY OF THORDON BEARINGS INC. ALL USE IS STRICTLY PROHIBITED UNLESS WRITTEN CONSENT IS OBTAINED FROM THORDON BEARINGS INC. THIS DRAWING IS THE PROPERTY OF THORDON BEARINGS INC. THIS DRAWING IS THE PROPERTY OF THORDON BEARINGS INC. THIS DRAWING IS THE PROPERTY OF THORDON BEARINGS INC.</small>							
DWG/ISS	THOR	DESIGNER	G. LE TOURNEAU	DATE	JAN 31/02	MRP NO.	F687557257
CUSTOMER/CLIENT	K. WRIGHT	CHKD/VER	I. ESTRADA	SIGN.		SIZE	B
						DRAWING NO. DU BESSIN	TO-15128
TITLE/TITRE	LOWER WICKET GATE BEARING						
						SHEET	3
						DE	3

ALL DIMENSIONAL INFORMATION IS BASED ON A MACHINING TEMPERATURE OF 21 °C, UNLESS STATED OTHERWISE. MACHINE GROOVES ONLY WHERE SHOWN

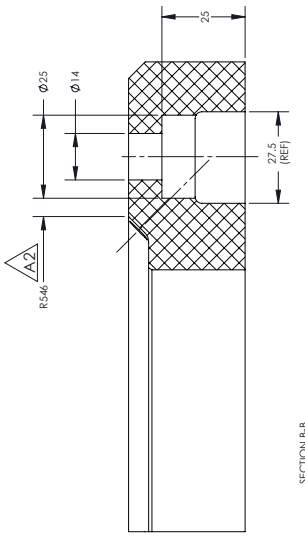

SECTION B-B

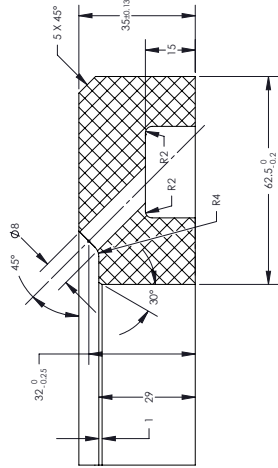

SECTION C-C

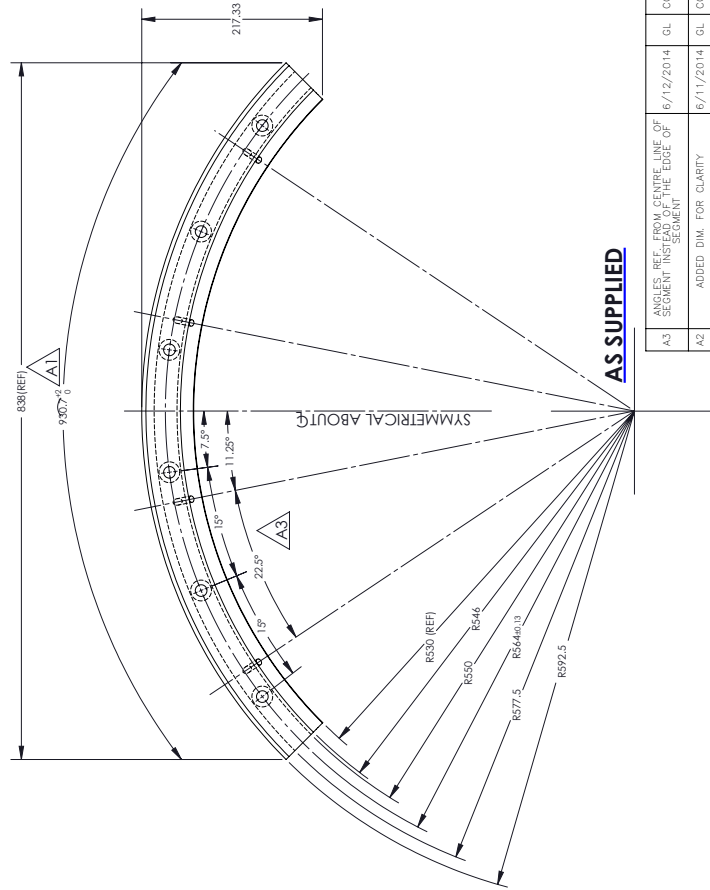

AS SUPPLIED

REV	DESCRIPTION	DATE	BY	CHK	APP
A3	ADDED DIM. FOR CLARITY	6/12/2014	GL	CCS	AS
A2	TOLERANCE WAS +0/-2	6/11/2014	GL	CCS	AS
A1		6/11/2014	GL	CCS	AS

MFG DRAWING NO. THORON SXL CUSTOMER/CLIENT: THORON BEARINGS INC.		DRAWING DATE: 21-02-2013 MRP NO.: F10037002	SIZE: C DRAWING NO. OR SEAL NO.: TG-23727
C. PREP: C. SWDN C. COSE		DRAWING SCALE: 1:1 DRAWING NO.: 1	SIZE: A DRAWING NO.: 1

AS INSTALLED

DO NOT SCALE THIS DRAWING. WORK TO DIMENSIONS SPECIFIED UNLESS SHOWN OTHERWISE. MACHINING TOLERANCES ARE:
 LINEAR UP TO 1mm (47) +0.2 mm (0.020)
 OVER 1mm (47) +1.0 mm (0.040)
 ANGULAR $\pm 0.25^\circ$
 SURFACE FINISH 3.2 $\mu\text{m Ra}$ (125 μinches)
 THORON MATERIAL SURFACE FINISH TO BE DETERMINED ONLY BY USE OF COMPANION

GENERAL NOTES:
 01. MATERIAL: THORON SXL
 02. DIMENSIONS: ALL DIMENSIONS ARE IN MM, UNLESS NOTED OTHERWISE.
 03. DO NOT SCALE THIS DRAWING. WORK TO DIMENSIONS SPECIFIED.
 04. TOLERANCES FOR ALL DIMENSIONS SHALL BE NON-CUMULATIVE.
 05. BREAK ALL CORNERS AND DEBURR ALL SHARP EDGES.
 06. ALL FILLET AND RADIUS DIMENSIONS ARE NOMINAL UNLESS NOTED OTHERWISE.

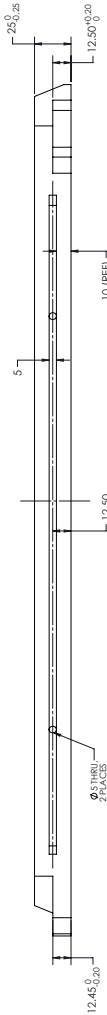
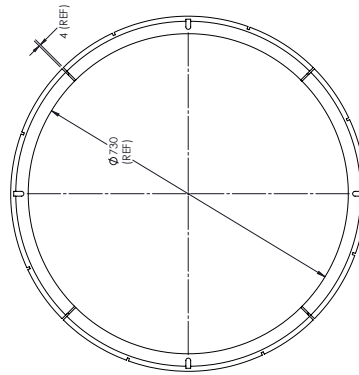
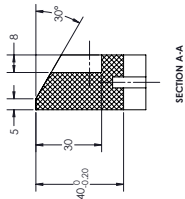
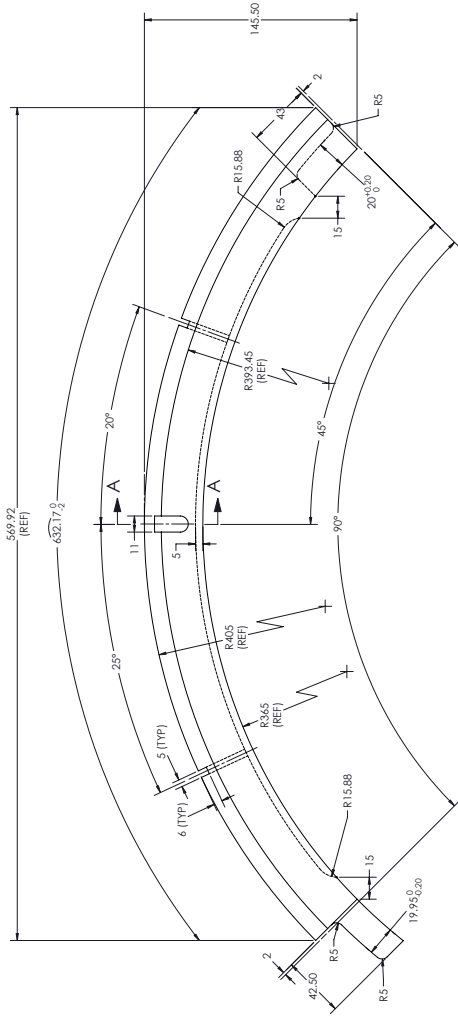

*AFF DIA. := 7.90
 OUBING DIA. := 850
 OUBING LENGTH := 76

SERIAL NO. :=

MATERIAL THORNDON SX
 1. DO NOT SCALE THIS DRAWING - WORK TO DIMENSIONS SPECIFIED.
 2. DIMENSIONS ARE IN MILLIMETERS UNLESS OTHERWISE NOTED.
 3. ALL DIMENSIONS ARE NOMINAL UNLESS NOTED OTHERWISE.

NOT FOR CUSTOMER

PROPOSAL DATE: 01-MAY-2015		DESCRIPTION: BIRMINGHAM, ONTARIO, CANADA
AV. P.A. / DATE:	DATE:	DRAWN BY:
CHECKED BY:	APPROVED BY:	PROJECT NO. / ORDER NO.:
THORNDON SX SEAL BEARING	CG 2740	SHEET: 1 OF 2

ITEM NO.	QTY.	DESCRIPTION	Material	REMARKS	DRAWING NUMBER
1	4	KEEPER BAR	BRONZE C95400		TC-25628
2	1	BEARING	THORDON SXL	SPLIT	TC-25659
3	32	DIN6912-M12X45	BRONZE C95400	BOLT, FLANGE, HEX HEAD	TC-25879
4	8	S.H.C.S.	ANSI 316 ST. STEEL	DIN912-M16X50 PURCHASE	
5	4	DOWEL PIN	ALLOY STEEL	5/8" X 1.5" LG.	
6	6	FLAT HEAD CAP SCREW	316 SS	M6 X 15 LG. UNSUNK CAP SCREW FULLY THREADED	

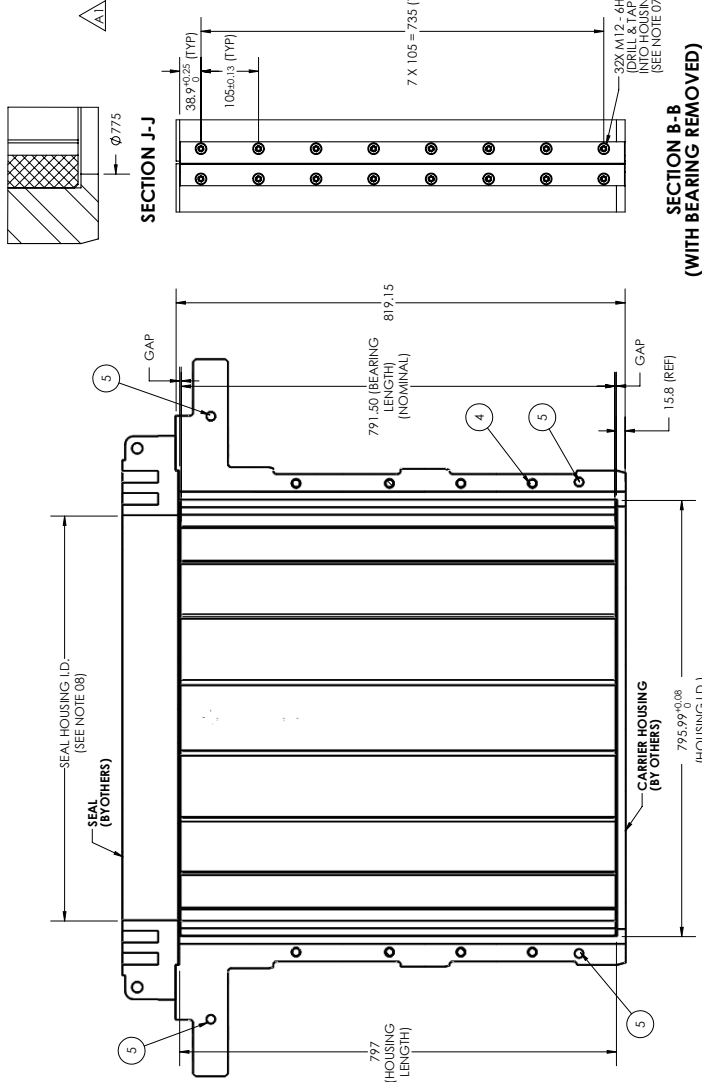

SECTION A-A
(WITH KEEPER BARS REMOVED)

SECTION B-B
(WITH BEARING REMOVED)

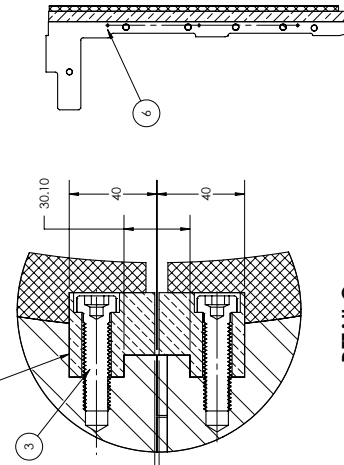

DETAIL C

- MINIMUM INSTALLED CLEARANCE: 0.67
- RUNNING CLEARANCE: 0.22
- THERMAL EXPANSION ALLOWANCE: 0.08
- WATER SWELL ALLOWANCE: 0.37
- TEMPERATURE RANGE: 30 °C TO 2°C (WITH KEY)
- SHAFT DIA.: = 740.07
- HOUSING DIA.: = 800.00
- HOUSING LENGTH: = 797.00

- GENERAL NOTES:**
01. MATERIAL - SEE PARTS LIST
 02. DIMENSIONS ARE EXPRESSED IN MM UNLESS NOTED OTHERWISE.
 03. DO NOT SCALE THIS DRAWING. WORK TO DIMENSIONS SPECIFIED.
 04. BREAK ALL EDGES AND SURFACES TO BE SHARPED.
 05. BREAK ALL CORNERS AND EDGES TO BE ROUNDED.
 06. ALL FILLET AND RADIUS DIMENSIONS ARE NOMINAL UNLESS NOTED OTHERWISE.
 07. EXISTING CARRIER TO BE MODIFIED AS INDICATED TO SUIT INTERFERENCE FIT BEARING AND KEEPER BAR DESIGN.
 08. SEAL HOUSING I.D. MUST PROVIDE ENOUGH CLEARANCE TO ALLOW FOR BEARING WEAR.

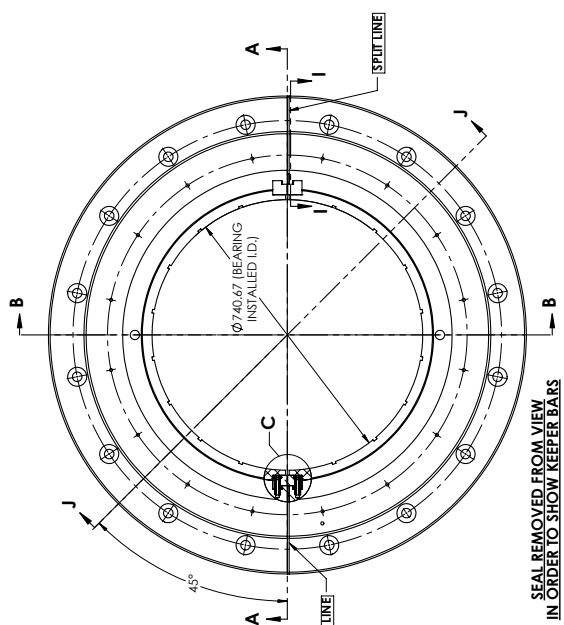

**SEAL REMOVED FROM VIEW
IN ORDER TO SHOW KEEPER BARS**

REV.	DESCRIPTION	DATE	DATE	CP	AS
B1	NO CHANGES TO THIS PAGE	19/01/2014			A
A2	NO CHANGES TO THIS PAGE	28/02/2014			A
A1	DRAWING NUMBER ADDED FOR LOW HEAD S.H.C.S.	28/02/2014			A

THORDON BEARINGS INC.
BURLINGTON, ONTARIO, CANADA

THIS DRAWING IS THE PROPERTY OF THORDON BEARINGS INC. ALL RIGHTS RESERVED WITHOUT PROPER WRITTEN CONSENT. NO PART OF THIS DRAWING IS TO BE REPRODUCED OR TRANSMITTED IN ANY FORM OR BY ANY MEANS, ELECTRONIC OR MECHANICAL, INCLUDING PHOTOCOPYING, RECORDING, OR BY ANY INFORMATION STORAGE AND RETRIEVAL SYSTEM, WITHOUT THE WRITTEN PERMISSION OF THORDON BEARINGS INC.

NO SCALE THE DRAWING. WORK TO DIMENSIONS SPECIFIED.
UNLESS OTHERWISE SPECIFIED, TOLERANCES ARE:
HORIZONTAL ± 0.10 (REF) ± 0.15 (MM) (H 001)
VERTICAL ± 0.10 (REF) ± 0.15 (MM) (H 004)
ANGULAR ± 0.25°
SURFACE FINISH: 3.2 µm Ra (125 µin) (WHERE SPECIFIED)
THORDON MATERIAL SURFACE FINISH TO BE DETERMINED BY USE OF COMPASS

OPTION 3

CUSTOMER/CLIENT: _____ DATE: 14-FEB-2014
DESIGNER: _____ DATE: _____
CHECKED: _____ DATE: _____
APPROVED: _____ DATE: _____

DRAWING NO. D042538
SHEET NO. 1 OF 2
DRAWING NO. D042538
SHEET NO. 1 OF 2

REV	QTY	DESCRIPTION	QUANTITY	REMARKS	DATE
1	1	BEARING	1	SHU	10/27/21
2	1	CARRIER & LIFT RING	1	SHU	10/27/21
3	1	WATER SEAL	1	SHU	10/27/21
4	1	WATER SEAL	1	SHU	10/27/21
5	1	WATER SEAL	1	SHU	10/27/21
6	1	WATER SEAL	1	SHU	10/27/21
7	1	WATER SEAL	1	SHU	10/27/21
8	1	WATER SEAL	1	SHU	10/27/21
9	1	WATER SEAL	1	SHU	10/27/21
10	1	WATER SEAL	1	SHU	10/27/21
11	1	WATER SEAL	1	SHU	10/27/21
12	1	WATER SEAL	1	SHU	10/27/21
13	1	WATER SEAL	1	SHU	10/27/21
14	1	WATER SEAL	1	SHU	10/27/21
15	1	WATER SEAL	1	SHU	10/27/21
16	1	WATER SEAL	1	SHU	10/27/21
17	1	WATER SEAL	1	SHU	10/27/21
18	1	WATER SEAL	1	SHU	10/27/21
19	1	WATER SEAL	1	SHU	10/27/21
20	1	WATER SEAL	1	SHU	10/27/21
21	1	WATER SEAL	1	SHU	10/27/21
22	1	WATER SEAL	1	SHU	10/27/21
23	1	WATER SEAL	1	SHU	10/27/21
24	1	WATER SEAL	1	SHU	10/27/21
25	1	WATER SEAL	1	SHU	10/27/21
26	1	WATER SEAL	1	SHU	10/27/21
27	1	WATER SEAL	1	SHU	10/27/21
28	1	WATER SEAL	1	SHU	10/27/21
29	1	WATER SEAL	1	SHU	10/27/21
30	1	WATER SEAL	1	SHU	10/27/21
31	1	WATER SEAL	1	SHU	10/27/21
32	1	WATER SEAL	1	SHU	10/27/21
33	1	WATER SEAL	1	SHU	10/27/21
34	1	WATER SEAL	1	SHU	10/27/21
35	1	WATER SEAL	1	SHU	10/27/21
36	1	WATER SEAL	1	SHU	10/27/21
37	1	WATER SEAL	1	SHU	10/27/21
38	1	WATER SEAL	1	SHU	10/27/21
39	1	WATER SEAL	1	SHU	10/27/21
40	1	WATER SEAL	1	SHU	10/27/21
41	1	WATER SEAL	1	SHU	10/27/21
42	1	WATER SEAL	1	SHU	10/27/21
43	1	WATER SEAL	1	SHU	10/27/21
44	1	WATER SEAL	1	SHU	10/27/21
45	1	WATER SEAL	1	SHU	10/27/21
46	1	WATER SEAL	1	SHU	10/27/21
47	1	WATER SEAL	1	SHU	10/27/21
48	1	WATER SEAL	1	SHU	10/27/21
49	1	WATER SEAL	1	SHU	10/27/21
50	1	WATER SEAL	1	SHU	10/27/21

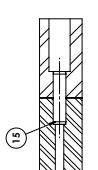
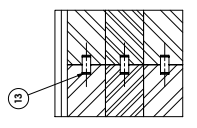
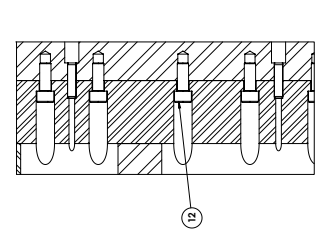
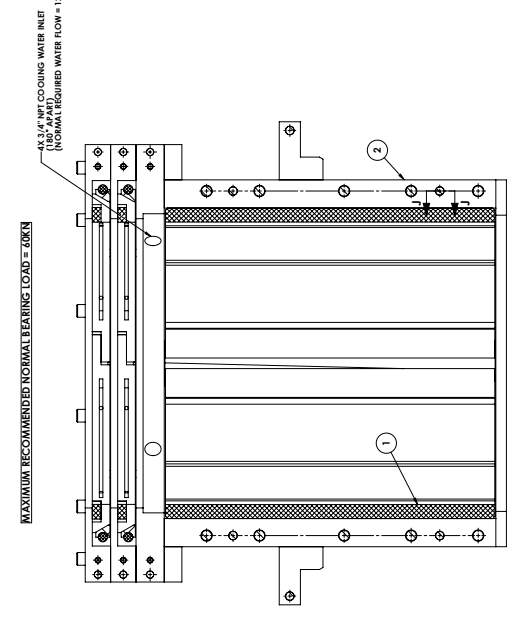
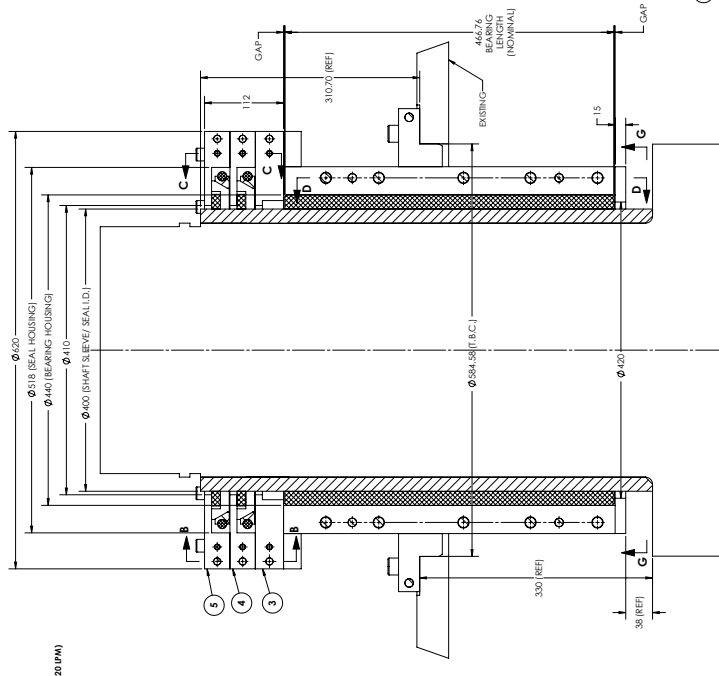

SECTION C-C

SECTION J-J

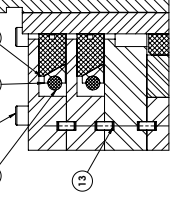
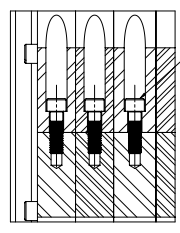

SECTION B-B

SECTION F-F

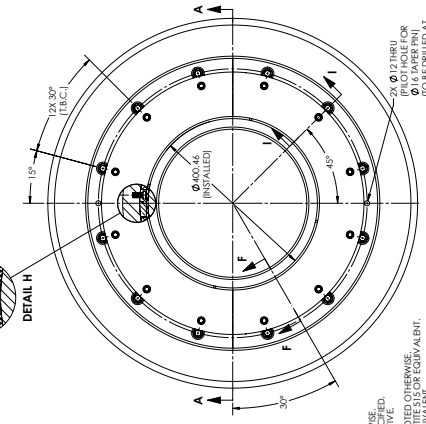

SECTION I-I

TOP VIEW

MINIMUM INSTALLED CLEARANCE:	0.46
RUNNING CLEARANCE:	0.16
THERMAL EXPANSION ALLOWANCE:	0.05
WATER SWELL ALLOWANCE:	0.25
TEMPERATURE RANGE:	30 °C TO 2°C
SHAFT DIA.:	400
HOUSING DIA.:	440
HOUSING LENGTH:	470

GENERAL NOTES:
01. MATERIAL: SEE PARTS LIST
02. DIMENSIONS ARE EXPRESSED IN MILLIMETERS UNLESS NOTED OTHERWISE.
03. DIMENSIONS FOR ALL DIMENSIONS SHALL BE NON-CUMULATIVE.
04. TOLERANCES FOR ALL DIMENSIONS SHALL BE UNLESS SPECIFIED.
05. ALL DIMENSIONS ARE NOMINAL UNLESS NOTED OTHERWISE.
06. ALL PARTS TO BE INSTALLED USING LOCITITE 240 OR EQUIVALENT.
07. TOTAL MASS OF COMPLETE ASSEMBLY = 4.80 KG.

PROPOSAL
DATE: 01/14/2021
FOR: [REDACTED]
BY: [REDACTED]

THORNDON BEARINGS INC.
1000 RIVERVIEW DRIVE
BURLINGTON, ONTARIO, CANADA
L7R 4A8
TEL: 905.335.3333
FAX: 905.335.3334
WWW.THORNDONBEARINGS.COM
THORNDON SIX
HOB B ASSEMBLY
DATE: 10/27/21

THORDON
THORDON BEARINGS INC.

ZERO POLLUTION | HIGH PERFORMANCE | BEARING & SEAL SYSTEMS

3225 Mainway, Burlington, Ontario L7M 1A6 Canada
Tel: +1.905.335.1440 Fax: +1.905.335.4033
www.ThordonBearings.com